



RED-RADIO

ETSI EN 300 328 V2.2.2 (2019-07)

TEST REPORT

Client Name : Shenzhen Newbit Information Technology Co., Ltd

Address : Room1612-Room 1616, Global Logistics Center Building,
Longgang Dist, Shenzhen

Product Name : Bluetooth Transmission Module

Test Model No. : XY-MBO21F

Report No. : CCTI-2024032809-1E

Issued Date : Apr. 01, 2024

Prepared By : Shenzhen CCTI Technology Co., Ltd.

Address : 7th Floor, Block A, Building E, Yongwei Industrial Park, No. 118,
Yongfu Road, Qiaotou, Fuhai Street, Bao'an District, Shenzhen,
Guangdong, China

Contact Info : Service Tel : 0086-400-188-9662
CCTI E-mail : ccti@ccti-lab.com
CCTI Web : www.ccti-lab.com



Scan code for report

TEST REPORT VERIFICATION

Applicant : Shenzhen Newbit Information Technology Co., Ltd
Address : Room1612-Room 1616, Global Logistics Center Building, Longgang Dist, Shenzhen
Manufacturer : Shenzhen Newbit Information Technology Co., Ltd
Address : Room1612-Room 1616, Global Logistics Center Building, Longgang Dist, Shenzhen
Product Name : Bluetooth Transmission Module
Model No. : XY-MBO21F
Series No. : XY-MBO26A
Trade Mark : N/A
Rating(s) : Input: DC 3.3V
Test Date : Mar. 25, 2024 to Apr. 01, 2024
Test Standard(s) : ETSI EN 300 328 V2.2.2 (2019-07)
Test Result : PASS

This device described above has been tested by CCTI, and the test results show that the equipment under test (EUT) is in compliance with the 2014/53/EU RED Directive Art.3.2 requirements. The results shown in this test report refer only to the sample(s) tested unless other wise stated and the sample(s) are retained for 30 days only. The document is issued by CCTI, may be altered or revised by CCTI, personal only, and shall be noted in the revision of the document. this document cannot be reproduced except in full with our prior written permission.

Producer By :

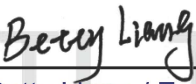
(Betty Liang / Engineer)

Date : Apr. 01, 2024

Authorized Signer :

(Corey Mao / Manager)

Date : Apr. 01, 2024



TABLE OF CONTENTS

1. TEST SUMMARY.....	5
2. MEASUREMENT UNCERTAINTY.....	6
3. PRODUCT INFORMATION AND TEST SETUP.....	7
3.1. Product Information.....	7
3.2. Test Setup Configuration.....	7
3.3. Support Equipment.....	7
3.4. Channel List.....	8
3.5. Test Mode.....	8
3.6. Test Environment.....	8
3.7. Test Description.....	9
4. TEST FACILITY AND TEST INSTRUMENT USED.....	10
4.1. Test Facility.....	10
4.2. Test Instrument Used.....	10
5. INFORMATION AS REQUIRED.....	13
6. RF Output Power.....	17
6.1. Block Diagram Of Test Setup.....	17
6.2. Limit.....	17
6.3. Test procedure.....	17
6.4. Test Description.....	19
6.5. Test Result.....	19
7. Power Spectral Density.....	20
7.1. Block Diagram of Test Setup.....	20
7.2. Limit.....	20
7.3. Test procedure.....	20
7.4. Test Description.....	22
7.5. Test Result.....	23
8. Duty Cycle, Tx-sequence, Tx-gap.....	25
8.1. Block Diagram of Test Setup.....	25
8.2. Limit.....	25
8.3. Test procedure.....	25
8.4. Test Result.....	26
9. Medium Utilisation (MU) factor.....	27
9.1. Block Diagram of Test Setup.....	27
9.2. Limit.....	27
9.3. Definition.....	27
9.4. Test procedure.....	27
9.5. Test Result.....	28
10. Occupied Channel Bandwidth.....	29
10.1. Block Diagram of Test Setup.....	29
10.2. Limit.....	29
10.3. Test procedures.....	29
10.4. Test Description.....	30

10.5. Test Result.....	30
11. Transmitter unwanted emissions in the out-of-band domain.....	31
11.1. Block Diagram of Test Setup.....	31
11.2. Limit.....	31
11.3. Test procedures.....	31
11.4. Test Description.....	33
11.5. Test Result.....	33
12. Transmitter unwanted emissions in the spurious domain.....	36
12.1. Block Diagram of Test Setup.....	36
12.2. Limit.....	37
12.3. Test Procedure.....	37
12.4. Test Result.....	38
13. Receiver spurious emissions.....	40
13.1. Block Diagram of Test Setup.....	40
13.2. Limit.....	40
13.3. Test Procedure.....	41
13.4. Test Results.....	42
14. Adaptivity (non-FHSS).....	44
14.1. Block Diagram of Test Setup.....	44
14.2. Limit.....	44
14.3. Test Procedure.....	45
14.4. Test Results.....	51
15. Receiver Blocking.....	52
15.1. Block Diagram of Test Setup.....	52
15.2. Limit.....	52
15.3. Test Procedure.....	53
15.4. Test Results.....	55
APPENDIX I -- EUT PHOTOGRAPHS.....	56
APPENDIX II -- EUT TEST PHOTOGRAPHS.....	58

1. TEST SUMMARY

The tests were performed according to following standards:

ETSI EN 300 328 V2.2.2 (2019-07) – Wideband transmission systems;

Data transmission equipment operating in the 2,4 GHz ISM band and using wide band modulation techniques; Harmonised Standard for access to radio spectrum:

No.	Test Parameter	Class/Severity	Results
Transmitter Parameters			
1	Maximum transmit power	EN 300 328 Clause 4.3.2.2	PASS
2	Power Spectral Density	EN 300 328 Clause 4.3.2.3	PASS
3	Duty Cycle, Tx-sequence, Tx-gap	EN 300 328 Clause 4.3.2.4	N/A <small>note1</small>
4	Medium Utilization (MU) factor	EN 300 328 Clause 4.3.2.5	N/A <small>note1</small>
5	Adaptivity (Adaptive Frequency Hopping)	EN 300 328 Clause 4.3.2.6	N/A <small>note2</small>
6	Occupied Channel Bandwidth	EN 300 328 Clause 4.3.2.7	PASS
7	Transmitter unwanted emissions in the out-of-band domain	EN 300 328 Clause 4.3.2.8	PASS
8	Transmitter unwanted emissions in the spurious domain	EN 300 328 Clause 4.3.2.9	PASS
Receiver Parameters			
9	Receiver spurious emissions	EN 300 328 Clause 4.3.2.11	PASS
10	Receiver Blocking	EN 300 328 Clause 4.3.2.12	PASS
11	Geo-location Capability	EN 300 328 Clause 4.3.2.13	N/A <small>note3</small>
<p>Note1: This requirement does not apply to adaptive equipment.</p> <p>Note2: Which is not applicable to device with a maximum RF Output power level is less than 10 dBm e.i.r.p.</p> <p>Note3: This equipment without geo-location capability function.</p>			

2. MEASUREMENT UNCERTAINTY

Where relevant, the following measurement uncertainty levels have been estimated for tests performed on the Product as specified in CISPR 16-4-2.

This uncertainty represents an expanded uncertainty expressed at approximately the 95% confidence level using a coverage factor of k=2.

Parameter	Expanded Uncertainty (Confidence of 95%)
Radiated Emission(9kHz-30MHz)	± 4.34dB
Radiated Emission(30Mz-1000MHz)	± 4.24dB
Radiated Emission(1GHz-18GHz)	± 4.68dB
AC Power Line Conducted Emission(150kHz-30MHz)	± 3.45dB

Parameter	Expanded Uncertainty (Confidence of 95%)
Occupied Channel Bandwidth	± 5%
RF output power, conducted	± 1.5dB
Power Spectral Density, conducted	± 3.0dB
Unwanted Emissions, conducted	± 3.0dB
Temperature	± 3°C
Supply voltages	± 3%
Time	± 5%
Unwanted Radiated Emission (30MHz ~ 1000MHz)	± 4.35dB
Unwanted Radiated Emission (1GHz ~ 18GHz)	± 4.44dB

3. PRODUCT INFORMATION AND TEST SETUP

3.1. Product Information

EUT Name	: Bluetooth Transmission Module
Trademark	: N/A
Model No.	: XY-MBO21F
Series No.	: XY-MBO26A
Model Difference	: The model and size of the product are different
Bluetooth Version	: Bluetooth Low Energy (BLE)
Operation Frequency	: 2402MHz-2480MHz
Channel number	: 40
Channel separation	: 1MHz
Type of Modulation	: GFSK
Antenna type	: PCB Antenna
Antenna Gain:	: Bluetooth: 1.0dBi
Power Supply	: Input: DC 3.3V

Remark:

- (1) XY-MBO21F was selected as the test model and the datas have been recorded in this report.
(2) For a more detailed features description, please refer to the manufacturer's specifications or the User's Manual.

3.2. Test Setup Configuration

See test photographs attached in EUT TEST SETUP PHOTOGRAPHS for the actual connections between Product and support equipment.

3.3. Support Equipment

No.	Device Type	Brand	Model	Series No.	Data Cable	Power Cord
-	-	-	-	-	-	-

Notes:

1. All the equipment/cables were placed in the worst-case configuration to maximize the emission during the test.
2. Grounding was established in accordance with the manufacturer's requirements and conditions for the intended use.

3.4. Channel List

Channel	Frequency(MHz)	Channel	Frequency(MHz)
00	2402	20	2442
01	2404	21	2444
02	2406	22	2446
03	2408	23	2448
04	2410	24	2450
05	2412	25	2452
06	2414	26	2454
07	2416	27	2456
08	2418	28	2458
09	2420	29	2460
10	2422	30	2462
11	2424	31	2464
12	2426	32	2466
13	2428	33	2468
14	2430	34	2470
15	2432	35	2472
16	2434	36	2474
17	2436	37	2476
18	2438	38	2478
19	2440	39	2480

3.5. Test Mode

All test mode(s) and condition(s) mentioned were considered and evaluated respectively by performing full tests, the worst data were recorded and reported.

Test mode	Test mode description
Transmitting (TX)	Keep the EUT in continuously transmitting mode.
Receiving (RX)	Keep the EUT in receiving mode

3.6. Test Environment

During the measurement the environmental conditions were within the listed ranges:

Temperature	Normal Temperature	25°C
	High Temperature	55°C
	Low Temperature	-20°C
Voltage	Normal Voltage	3.3V
	High Voltage	3.63V
	Low Voltage	2.97V
Other	Relative Humidity	55 %
	Air Pressure	101 kPa

3.7. Test Description

3.7.1. Main Terms

Verdict Verdict of each test cases.

Test Case Test cases identification number and description in ETSI specification.

3.7.2. Terms used in Condition column

NTC Normal voltage, Normal Temperature

HTHV High voltage, High Temperature

LTHV High voltage, Low Temperature

HTLV Low voltage, High Temperature

LTLV Low voltage, Low Temperature



4. TEST FACILITY AND TEST INSTRUMENT USED

4.1. Test Facility

Shenzhen CCTI Technology Co., Ltd.

7th Floor, Block A, Building E, Yongwei Industrial Park, No. 118, Yongfu Road, Qiaotou, Fuhai Street, Bao'an District, Shenzhen, Guangdong, China

4.2. Test Instrument Used

Test Equipment Of Receiver Blocking					
Equipment	Manufacturer	Type No.	Serial No.	Last Cal.	Next Cal.
Spectrum	R&S	FSP40	100817	Mar. 09, 2024	Mar. 08, 2025
Spectrum	Agilent	N9020A	MY49100060	Mar. 09, 2024	Mar. 08, 2025
Signal Generator	Agilent	N5182A	MY49060650	Mar. 09, 2024	Mar. 08, 2025
Signal Generator	Agilent	E8257D	MY44320250	Mar. 09, 2024	Mar. 08, 2025

Test Equipment Of Receiver spurious emissions					
Equipment	Manufacturer	Type No.	Serial No.	Last Cal.	Next Cal.
Chamber	SKET	966	N/A	Mar. 09, 2024	Mar. 08, 2025
Spectrum	R&S	FSP40	100817	Mar. 09, 2024	Mar. 08, 2025
Receiver	R&S	ESR7	101199	Mar. 09, 2024	Mar. 08, 2025
Broadband Antenna	Schwarzbeck	VULB9168	00836 P:00227	Mar. 09, 2024	Mar. 08, 2025
Horn Antenna	Schwarzbeck	9120D	01892 P:00331	Mar. 09, 2024	Mar. 08, 2025
Amplifier	SKET	PA-000318G-45	N/A	Mar. 09, 2024	Mar. 08, 2025
EMI software	EZ	EZ-EMC	EEMC-3A1	N/A	N/A
Loop antenna	SCHNARZBECK	FMZB1519B	00102	Mar. 09, 2024	Mar. 08, 2025
Controller	SKET	N/A	N/A	N/A	N/A
Coaxial Cable	BlueAsia	BLA-XC-02	N/A	N/A	N/A
Coaxial Cable	BlueAsia	BLA-XC-03	N/A	N/A	N/A
Coaxial Cable	BlueAsia	BLA-XC-01	N/A	N/A	N/A

Test Equipment Of Transmitter unwanted emissions in the spurious domain					
Equipment	Manufacturer	Type No.	Serial No.	Last Cal.	Next Cal.
Chamber	SKET	966	N/A	Mar. 09, 2024	Mar. 08, 2025

Spectrum	R&S	FSP40	100817	Mar. 09, 2024	Mar. 08, 2025
Receiver	R&S	ESR7	101199	Mar. 09, 2024	Mar. 08, 2025
Broadband Antenna	Schwarzbeck	VULB9168	00836 P:00227	Mar. 09, 2024	Mar. 08, 2025
Horn Antenna	Schwarzbeck	9120D	01892 P:00331	Mar. 09, 2024	Mar. 08, 2025
Amplifier	SKET	PA-000318G-45	N/A	Mar. 09, 2024	Mar. 08, 2025
EMI software	EZ	EZ-EMC	EEMC-3A1	N/A	N/A
Loop antenna	SCHNARZBECK	FMZB1519B	00102	Mar. 09, 2024	Mar. 08, 2025
Controller	SKET	N/A	N/A	N/A	N/A
Coaxial Cable	BlueAsia	BLA-XC-02	N/A	N/A	N/A
Coaxial Cable	BlueAsia	BLA-XC-03	N/A	N/A	N/A
Coaxial Cable	BlueAsia	BLA-XC-01	N/A	N/A	N/A

Test Equipment Of Transmitter unwanted emissions in the out-of-band domain

Equipment	Manufacturer	Type No.	Serial No.	Last Cal.	Next Cal.
Spectrum	R&S	FSP40	100817	Mar. 09, 2024	Mar. 08, 2025
Spectrum	Agilent	N9020A	MY49100060	Mar. 09, 2024	Mar. 08, 2025
Signal Generator	Agilent	N5182A	MY49060650	Mar. 09, 2024	Mar. 08, 2025
Signal Generator	Agilent	E8257D	MY44320250	Mar. 09, 2024	Mar. 08, 2025
Power probe	DARE	RPR3006W	14I00889SN042	Mar. 09, 2024	Mar. 08, 2025

Test Equipment Of Occupied Channel Bandwidth

Equipment	Manufacturer	Type No.	Serial No.	Last Cal.	Next Cal.
Spectrum	R&S	FSP40	100817	Mar. 09, 2024	Mar. 08, 2025
Spectrum	Agilent	N9020A	MY49100060	Mar. 09, 2024	Mar. 08, 2025
Signal Generator	Agilent	N5182A	MY49060650	Mar. 09, 2024	Mar. 08, 2025
Signal Generator	Agilent	E8257D	MY44320250	Mar. 09, 2024	Mar. 08, 2025
Power probe	DARE	RPR3006W	14I00889SN042	Mar. 09, 2024	Mar. 08, 2025

Test Equipment Of Hopping Frequency Separation

Equipment	Manufacturer	Type No.	Serial No.	Last Cal.	Next Cal.
Spectrum	R&S	FSP40	100817	Mar. 09, 2024	Mar. 08, 2025
Spectrum	Agilent	N9020A	MY49100060	Mar. 09, 2024	Mar. 08, 2025
Signal Generator	Agilent	N5182A	MY49060650	Mar. 09, 2024	Mar. 08, 2025

Signal Generator	Agilent	E8257D	MY44320250	Mar. 09, 2024	Mar. 08, 2025
Power probe	DARE	RPR3006W	14I00889SN042	Mar. 09, 2024	Mar. 08, 2025

Test Equipment Of Accumulated Transmit Time, Frequency Occupation and Hopping Sequence					
Equipment	Manufacturer	Type No.	Serial No.	Last Cal.	Next Cal.
Spectrum	R&S	FSP40	100817	Mar. 09, 2024	Mar. 08, 2025
Spectrum	Agilent	N9020A	MY49100060	Mar. 09, 2024	Mar. 08, 2025
Signal Generator	Agilent	N5182A	MY49060650	Mar. 09, 2024	Mar. 08, 2025
Signal Generator	Agilent	E8257D	MY44320250	Mar. 09, 2024	Mar. 08, 2025
Power probe	DARE	RPR3006W	14I00889SN042	Mar. 09, 2024	Mar. 08, 2025

Test Equipment Of RF Output Power					
Equipment	Manufacturer	Type No.	Serial No.	Last Cal.	Next Cal.
Spectrum	R&S	FSP40	100817	Mar. 09, 2024	Mar. 08, 2025
Spectrum	Agilent	N9020A	MY49100060	Mar. 09, 2024	Mar. 08, 2025
Signal Generator	Agilent	N5182A	MY49060650	Mar. 09, 2024	Mar. 08, 2025
Signal Generator	Agilent	E8257D	MY44320250	Mar. 09, 2024	Mar. 08, 2025
Power probe	DARE	RPR3006W	14I00889SN042	Mar. 09, 2024	Mar. 08, 2025

5. INFORMATION AS REQUIRED

ETSI EN 300 328 V2.2.2 Annex E

a) The type of modulation used by the equipment:

- FHSS
- non-FHSS

b) In case of FHSS :

- In case of non-Adaptive FHSS equipment:
The number of Hopping Frequencies:
- In case of Adaptive Frequency Hopping Equipment:
The maximum number of Hopping Frequencies:
The minimum number of Hopping Frequencies:
- The (average) Dwell Time:
The Minimum Channel Occupation Time:

c) Adaptive / non-adaptive equipment:

- non-adaptive Equipment
- adaptive Equipment without the possibility to switch to a non-adaptive mode adaptive
- Equipment which can also operate in a non-adaptive mode

d) In case of adaptive equipment:

- The maximum Channel Occupancy Time implemented by the equipment: ms
- The equipment has implemented an LBT based DAA mechanism
 - In case of equipment using modulation different from FHSS:
 - The equipment is Frame Based equipment
 - The equipment is Load Based equipment
 - The equipment can switch dynamically between Frame Based and Load Based equipment
 - The CCA time implemented by the equipment: μ s
 - The equipment has implemented an non-LBT based DAA mechanism
 - The equipment can operate in more than one adaptive mode

e) In case of non-adaptive Equipment:

- The maximum RF Output Power (e.i.r.p.): dBm
- The maximum (corresponding) Duty Cycle: %
- Equipment with dynamic behaviour, that behaviour is described here. (e.g. the different combinations of duty cycle and corresponding power levels to be declared):

f) The worst case operational mode for each of the following tests:

- RF Output Power: GFSK
- Power Spectral Density: GFSK
- Duty cycle, Tx-Sequence, Tx-gap:
- Accumulated Transmit time, Frequency Occupation & Hopping Sequence (only for FHSS equipment):
- Hopping Frequency Separation (only for FHSS equipment):

- Medium Utilization: GFSK
- Adaptivity & Receiver Blocking:
- Occupied Channel Bandwidth: GFSK
- Transmitter unwanted emissions in the OOB domain: GFSK
- Transmitter unwanted emissions in the spurious domain: GFSK
- Receiver spurious emissions : GFSK

g) The different transmit operating modes (tick all that apply):

- Operating mode 1: Single Antenna Equipment
 - Equipment with only one antenna
 - Equipment with two diversity antennas but only one antenna active at any moment in time
 - Smart Antenna Systems with two or more antennas, but operating in a (legacy) mode where only
 - One antenna is used (es.g. IEEE 802.11™ legacy mode in smart antenna systems)
- Operating mode 2: Smart Antenna Systems - Multiple Antennas without beam forming
 - Single spatial stream / Standard throughput / (e.g. IEEE 802.11™ legacy mode)
 - High Throughput (> 1 spatial stream) using Nominal Channel Bandwidth 1
 - High Throughput (> 1 spatial stream) using Nominal Channel Bandwidth 2

NOTE 1: Add more lines if more channel bandwidths are supported.

- Operating mode 3: Smart Antenna Systems - Multiple Antennas with beam forming
 - Single spatial stream / Standard throughput (e.g. IEEE 802.11™ [i.3] legacy mode)
 - High Throughput (> 1 spatial stream) using Nominal Channel Bandwidth 1
 - High Throughput (> 1 spatial stream) using Nominal Channel Bandwidth 2

NOTE 2: Add more lines if more channel bandwidths are supported.

h) In case of Smart Antenna Systems:

The number of Receive chains:

The number of Transmit chains:

- symmetrical power distribution
- asymmetrical power distribution

In case of beam forming, the maximum (additional) beam forming gain:

NOTE: The additional beam forming gain does not include the basic gain of a single antenna.

i) Operating Frequency Range(s) of the equipment:

Operating Frequency Range 1: 2402 MHz to 2480 MHz

Operating Frequency Range 2: MHz to MHz

NOTE: Add more lines if more Frequency Ranges are supported.

j) Nominal Channel Bandwidth(s):

- Occupied Channel Bandwidth 1: 1.401 MHz Max.
- Occupied Channel Bandwidth 2: MHz

NOTE: Add more lines if more channel bandwidths are supported.

k) Type of Equipment (stand-alone, combined, plug-in radio device, etc.):

- Stand-alone

- Combined Equipment (Equipment where the radio part is fully integrated within another type of equipment)
 Plug-in radio device (Equipment intended for a variety of host systems)
 Other

l) The normal and the extreme operating conditions that apply to the equipment:

- Operating temperature range: -10° C to 40° C
 Operating voltage range: 2.97V to 3.63V AC DC
 Details provided are for the: stand-alone equipment
 combined (or host) equipment
 test jig

m) The intended combination(s) of the radio equipment power settings and one or more antenna assemblies and their corresponding e.i.r.p. levels:

Antenna Type:

-
- Internal antenna

Antenna Gain: Refer to section 4.1

If applicable, additional beamforming gain (excluding basic antenna gain): dBm

- Temporary RF connector provided
 No temporary RF connector provided

Dedicated Antennas (equipment with antenna connector)

- Single power level with corresponding antenna(s)
 Multiple power settings and corresponding antenna(s)

Number of different Power Levels:

Power Level 1: dBm

Power Level 2: dBm

Power Level 3: dBm

NOTE 1: Add more lines in case the equipment has more power levels.

NOTE 2: These power levels are conducted power levels (at antenna connector).

For each of the Power Levels, provide the intended antenna assemblies, their corresponding gains (G) and the resulting e.i.r.p. levels also taking into account the beamforming gain (Y) if applicable

Power Level 1:

Number of antenna assemblies provided for this power level:

Assembly #	Gain (dBi)	E.i.r.p.(dBm)	Part number or model name
1	1.0	4.17	
2			
3			
4			

NOTE 3: Add more rows in case more antenna assemblies are supported for this power level.

Power Level 2:

Number of antenna assemblies provided for this power level:

Assembly #	Gain (dBi)	E.i.r.p.(dBm)	Part number or model name
1			

2			
3			
4			

NOTE 4: Add more rows in case more antenna assemblies are supported for this power level.

Power Level 3:

Number of antenna assemblies provided for this power level:

Assembly #	Gain (dBi)	E.i.r.p.(dBm)	Part number or model name
1			
2			
3			
4			

NOTE 5: Add more rows in case more antenna assemblies are supported for this power level.

n) The nominal voltages of the stand-alone radio equipment or the nominal voltages of the combined (host) equipment or test jig in case of plug-in devices:

Details provided are for the: stand-alone equipment
 combined (or host) equipment
 test jig

Supply Voltage: AC mains State AC voltage :.....V
 DC State DC voltage :3.3V

In case of DC, indicate the type of power source

- Internal Power Supply
 External Power Supply or AC/DC adapter
 Battery: 3.7V
 Other:

o) Describe the test modes available which can facilitate testing:

The EUT can transmit with test software which named CSR BlueSuite

p) The equipment type (e.g. Bluetooth®, IEEE 802.11™ [i.3], IEEE 802.15.4™ [i.4], proprietary, etc.):

Other: NO FHSS

q) If applicable, the statistical analysis referred to in clause 5.4.1 q)

(to be provided as separate attachment)

r) If applicable, the statistical analysis referred to in clause 5.4.1 r)

(to be provided as separate attachment)

s) Geo-location capability supported by the equipment:

Yes

The geographical location determined by the equipment as defined in clause 4.3.1.13.2 or clause 4.3.2.12.2 is not accessible to the user

No

6. RF OUTPUT POWER

6.1. Block Diagram Of Test Setup

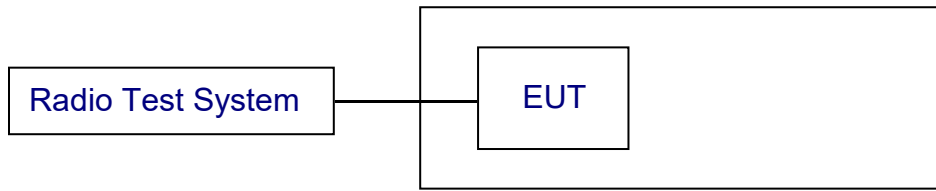

6.2. Limit

ETSI EN 300 328 V2.2.2 (2019-07) Sub-clause 4.3.2.2.3

The RF output power for FHSS equipment shall be equal to or less than 20 dBm.

NOTE: For Non-adaptive FHSS equipment, the manufacturer may have declared a reduced RF Output Power (see clause 5.4.1 m)) and associated Duty Cycle (see clause 5.4.1 e)) that will ensure that the equipment meets the requirement for the Medium Utilization (MU) factor further described in clause 4.3.1.6. This is verified by the conformance test referred to in clause 4.3.1.6.4.

For non-adaptive FHSS equipment, where the manufacturer has declared an RF output power lower than 20 dBm e.i.r.p., the RF output power shall be equal to or less than that declared value.

This limit shall apply for any combination of power level and intended antenna assembly.

Limit
20dBm

6.3. Test procedure

Step 1:

Use a fast power sensor with a minimum sensitivity of -40 dBm and capable of minimum 1 MS/s.

Use the following settings:

-Sample speed 1 MS/s or faster.

-The samples shall represent the RMS power of the signal.

-Measurement duration: For non-adaptive equipment: equal to the observation period defined in clause 4.3.1.3.2 or clause 4.3.2.4.2. For adaptive equipment, the measurement duration shall be long enough to ensure a minimum number of bursts (at least 10) are captured.

NOTE 1: For adaptive equipment, to increase the measurement accuracy, a higher number of bursts may be used.

Step 2:

For conducted measurements on devices with one transmit chain:

- Connect the power sensor to the transmit port, sample the transmit signal and store the raw data. Use these stored samples in all following steps.

For conducted measurements on devices with multiple transmit chains:

- Connect one power sensor to each transmit port for a synchronous measurement on all transmit ports.

- Trigger the power sensors so that they start sampling at the same time. Make sure the time difference between the samples of all sensors is less than 500 ns.

- For each individual sampling point (time domain), sum the coincident power samples of all ports and store them. Use these summed samples as the new stored data set.

Step 3:

Find the start and stop times of each burst in the stored measurement samples.

The start and stop times are defined as the points where the power is at least 30 dB below the highest value of the stored samples in step 2.

In case of insufficient sensitivity of the power sensor (e.g. in case of radiated measurements), the value of 30 dB may need to be reduced appropriately.

Step 4:

Between the start and stop times of each individual burst calculate the RMS power over the burst using the formula below. The start and stop points shall be included. Save these Pburst values, as well as the start and stop times for each burst.

$$P_{burst} = \frac{1}{k} \sum_{n=1}^k P_{sample}(n)$$

with 'k' being the total number of samples and 'n' the actual sample number

Step 5:

- The highest of all Pburst values (value "A" in dBm) will be used for maximum e.i.r.p. calculations.

Step 6:

- Add the (stated) antenna assembly gain "G" in dBi of the individual antenna.

- In case of smart antenna systems operating in mode with beamforming (see clause 5.3.2.2.4), add the additional beamforming gain Y in dB.

- If more than one antenna assembly is intended for this power setting, the maximum overall antenna gain (G or G + Y) shall be used.

- The RF Output Power (Pout) shall be calculated using the formula below::

$$P_{out} = A + G + Y$$

- This value, which shall comply with the limit given in clause 4.3.1.2.3 or clause 4.3.2.2.3, shall be recorded in the test report.

6.4. Test Description

Mode	BT Test mode
Test Channel	Channel 00(2402MHz), Channel 19(2440MHz), Channel 39(2480MHz)
Packet Type	Longest supported
Modulation	GFSK

6.5. Test Result

Test Mode	Test Condition	Antenna Measured Power (dBm)	EIRP(dBm)	Limit(dBm)
00	NTC	3.77	3.77	20
	LT/NV	3.62	3.62	20
	HT/NV	3.14	3.14	20
19	NTC	4.17	4.17	20
	LT/NV	3.99	3.99	20
	HT/NV	3.75	3.75	20
39	NTC	3.96	3.96	20
	LT/NV	3.61	3.61	20
	HT/NV	3.43	3.43	20
Result		Pass		

Note: Cable loss and antenna gain was combined in the calculated result.



7. Power Spectral Density

7.1. Block Diagram of Test Setup

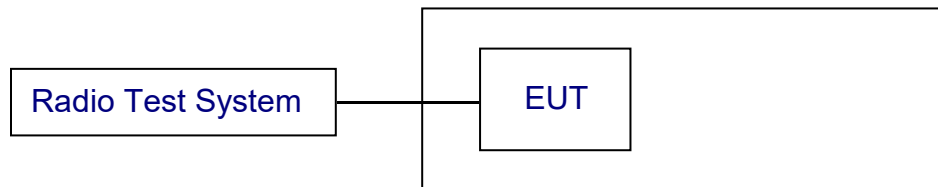

7.2. Limit

ETSI EN 300 328 V2.2.2 (2019-07) Sub-clause 4.3.2.3.3

The maximum Power Spectral Density for non-FHSS equipment is 10 dBm per MHz.

7.3. Test procedure

Option 1: For equipment with continuous and non-continuous transmissions

The transmitter shall be connected to a spectrum analyser and the Power Spectral Density (PSD) as defined in clause 4.3.2.3 shall be measured and recorded.

The test procedure shall be as follows:

Step 1:

- Connect the UUT to the spectrum analyser and use the following settings:
- Start Frequency: 2 400 MHz
- Stop Frequency: 2 483,5 MHz
- Resolution BW: 10 kHz
- Video BW: 30 kHz
- Sweep Points: > 8 350; for spectrum analysers not supporting this number of sweep points, the frequency band may be segmented
- Detector: RMS
- Trace Mode: Max Hold
- Sweep time: For non-continuous transmissions: $2 \times \text{Channel Occupancy Time} \times \text{number of sweep points}$

For continuous transmissions: 10 s; the sweep time may be increased further until a value where the sweep time has no further impact anymore on the RMS value of the signal.

For non-continuous signals, wait for the trace to stabilize. Save the data (trace data) set to a file.

Step 2:

For conducted measurements on smart antenna systems using either operating mode 2 or operating mode 3 (see clause 5.3.2.2), repeat the measurement for each of the transmit ports. For each sampling point (frequency domain), add up the coincident power values (in mW) for the different transmit chains and use this as the new data set.

Step 3:

Add up the values for power for all the samples in the file using the formula below.

$$P_{Sum} = \sum_{n=1}^k P_{sample}(n)$$

with k being the total number of samples and n the actual sample number

Step 4:

Normalize the individual values for power (in dBm) so that the sum is equal to the RF Output Power (e.i.r.p.) measured in clause 5.4.2 and save the corrected data. The following formulas can be used:

$$C_{Corr} = P_{Sum} - P_{e.i.r.p.}$$
$$P_{Samplecorr}(n) = P_{Sample}(n) - C_{Corr}$$

with n being the actual sample number

Step 5:

Starting from the first sample $P_{Samplecorr}^{(n)}$ (lowest frequency), add up the power (in mW) of the following samples representing a 1 MHz segment and record the results for power and position (i.e. sample #1 to sample #100). This is the Power Spectral Density (e.i.r.p.) for the first 1 MHz segment which shall be recorded.

Step 6:

Shift the start point of the samples added up in step 5 by one sample and repeat the procedure in step 5 (i.e. sample #2 to sample #101).

Step 7:

Repeat step 6 until the end of the data set and record the Power Spectral Density values for each of the 1 MHz segments. From all the recorded results, the highest value is the maximum Power Spectral Density (PSD) for the UUT. This value, which shall comply with the limit given in clause 4.3.2.3.3, shall be recorded in the test report.

Option 2: For equipment with continuous transmission capability or for equipment operating (or with the capability to operate) with a constant duty cycle (e.g. Frame Based equipment)

This option is for equipment that can be configured to operate in a continuous transmit mode (100 % DC) or with a constant Duty Cycle (DC).

Step 1:

- Connect the UUT to the spectrum analyser and use the following settings:
 - Centre Frequency: The centre frequency of the channel under test
 - RBW: 1 MHz
 - VBW: 3 MHz
 - Frequency Span: 2 × Nominal Bandwidth (e.g. 40 MHz for a 20 MHz channel)

- Detector Mode: Peak
- Trace Mode: Max Hold

Step 2:

- When the trace is complete, find the peak value of the power envelope and record the frequency.

Step 3:

- Make the following changes to the settings of the spectrum analyser:
 - Centre Frequency: Equal to the frequency recorded in step 2
 - Frequency Span: 3 MHz
 - RBW: 1 MHz
 - VBW: 3 MHz
 - Sweep Time: 1 minute
 - Detector Mode: RMS
 - Trace Mode: Max Hold

Step 4:

- Wait until the trace has stabilized, the trace shall be captured using the "Hold" or "View" option on the spectrum analyser.
- Find the peak value of the trace and place the analyser marker on this peak. This level is recorded as the highest mean power (power spectral density) D in a 1 MHz band.
- Alternatively, where a spectrum analyser is equipped with a function to measure power spectral density, this function may be used to display the power spectral density D in dBm / MHz.
- In case of conducted measurements on smart antenna systems operating in a mode with multiple transmit chains active simultaneously, the power spectral density of each transmit chain shall be measured separately to calculate the total power spectral density (value D in dBm / MHz) for the UUT.

Step 5:

- The maximum Power Spectral Density (PSD) e.i.r.p. is calculated from the above measured power spectral density D, the observed Duty Cycle (DC), the applicable antenna assembly gain G in dBi and if applicable the beamforming gain Y in dB, according to the formula below. The Duty Cycle (DC) can be determined using the procedure defined in clause 5.4.2.2.1.3). This value shall be recorded in the test report. If more than one antenna assembly is intended for this power setting, the gain of the antenna assembly with the highest gain shall be used.

$$PSD = D + G + Y + 10 \times \log (1 / DC) \text{ (dBm / MHz)}$$

7.4. Test Description

Mode	BT Test mode
Test Channel	Channel 00(2402MHz), Channel 19(2440MHz), Channel 39(2480MHz)
Modulation	GFSK

7.5. Test Result

The Maximum Power Spectral Density				
Test Channel Number	Test Condition	Measured Power Density (dBm/MHZ)	EIRP Density (dBm/MHz)	Limit (dBm/MHz)
00	NTC	3.70	3.70	10
19	NTC	4.11	4.11	10
39	NTC	3.89	3.89	10
Result		Pass		

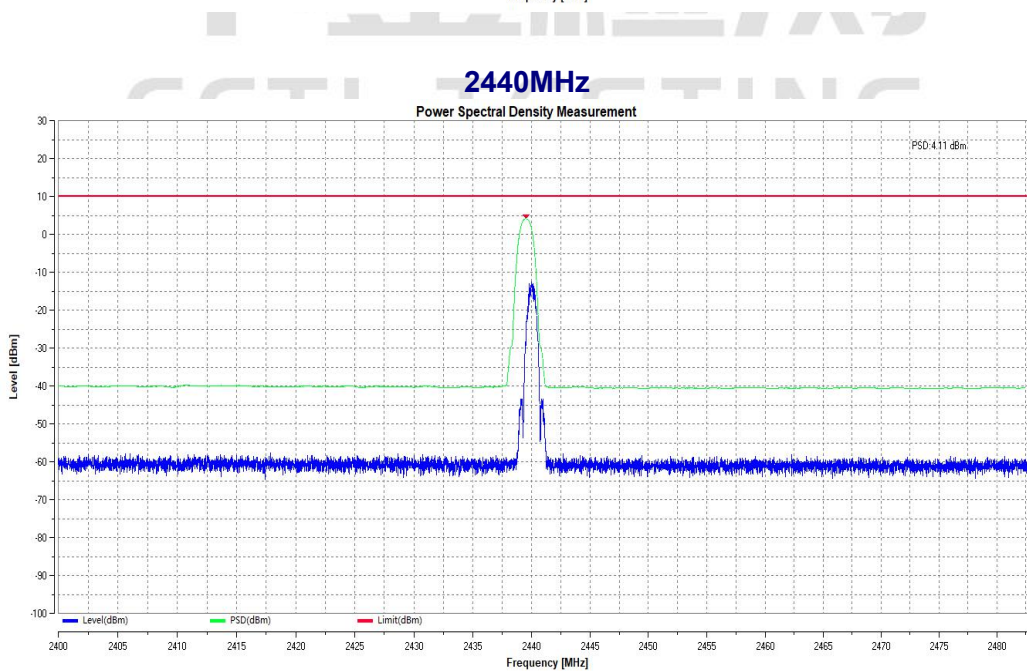
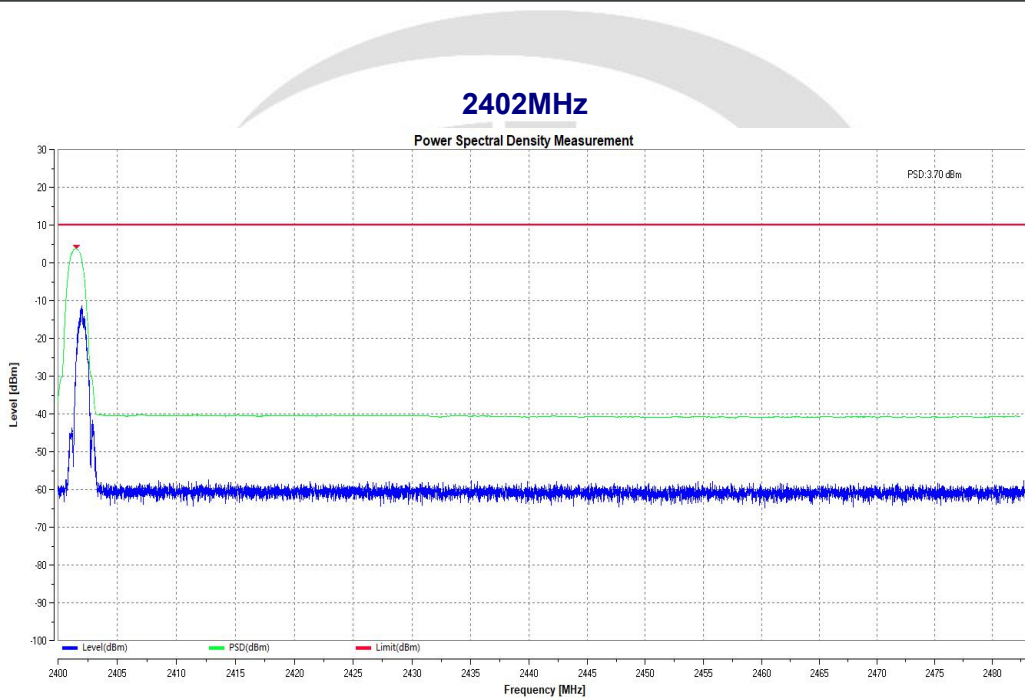

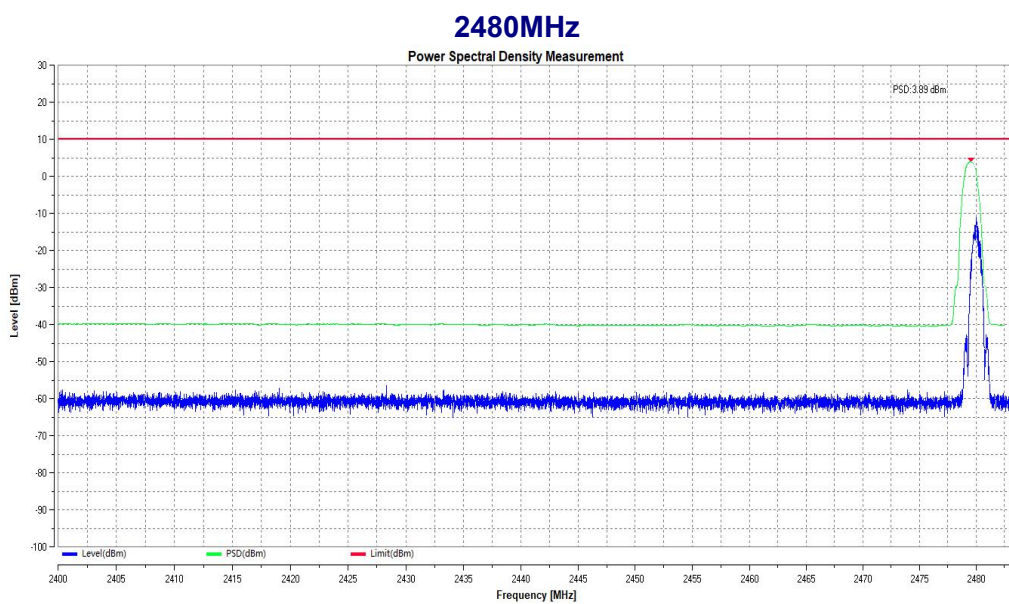

8. Duty Cycle, Tx-sequence, Tx-gap

8.1. Block Diagram of Test Setup

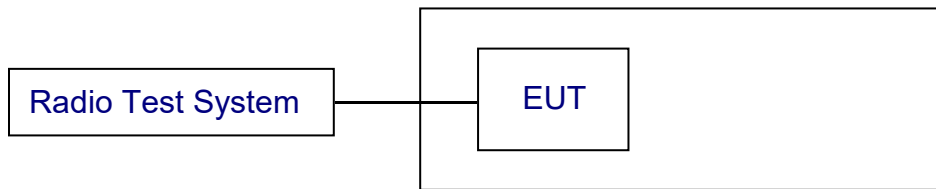

8.2. Limit

ETSI EN 300 328 V2.2.2 (2019-07) Sub-clause 4.3.2.4.3

The Duty Cycle shall be equal to or less than the maximum value declared by the manufacturer. The Tx-sequence time shall be equal to or less than 10 ms. The minimum Tx-gap time following a Tx-sequence shall be equal to the duration of that preceding Tx-sequence with a minimum of 3,5 ms.

8.3. Test procedure

The test procedure, which shall only be performed for non-adaptive equipment, shall be as follows:

Step 1:

- Use the same stored measurement samples from the procedure described in clause 5.4.2.2.1.2.
- The start and stop times are defined as the points where the power is at least 30 dB below the highest value of the stored samples. In case of insufficient dynamic range, the value of 30 dB may need to be reduced appropriately.

Step 2:

- Between the saved start and stop times of each individual burst, calculate the TxOn time. Save these TxOn values.

Step 3:

- Duty Cycle (DC) is the sum of all TxOn times between the end of the first gap (which is the start of the first burst within the observation period) and the start of the last burst (within this observation period) divided by the observation period. The observation period is defined in clause 4.3.1.3.2 or clause 4.3.2.4.2.

Step 4:

- For FHSS equipment using blacklisting, the TxOn time measured for a single (and active) hopping frequency shall be multiplied by the number of blacklisted frequencies. This value shall be added to the sum calculated in step 3 above. If the number of blacklisted frequencies cannot be determined, the minimum number of hopping frequencies (N) as defined in clause 4.3.1.4.3 shall be assumed.
- The calculated value for Duty Cycle (DC) shall be recorded in the test report. This

value shall be equal to or less than the maximum value declared by the manufacturer.

Step 5:

- Use the same stored measurement samples from the procedure described in clause 5.4.2.2.1.2.
- Identify any TxOff time that is equal to or greater than the minimum Tx-gap time as defined in clause 4.3.1.3.3 or clause 4.3.2.4.3. These are the potential valid gap times to be further considered in this procedure.
- Starting from the second identified gap, calculate the time from the start of this gap to the end of the preceding gap. This time is the Tx-sequence time for this transmission. Repeat this procedure until the last identified gap within the observation period is reached.
- A combination of consecutive Tx-sequence times and Tx-gap times followed by a Tx-gap time, which is at least as long as the duration of this combination, may be considered as a single Tx-sequence time and in which case it shall comply with the limits defined in clause 4.3.1.3.3 or clause 4.3.2.4.3.
- It shall be noted in the test report whether the UUT complies with the limits for the maximum Tx-sequence time and minimum Tx-gap time as defined in clause 4.3.1.3.3 or clause 4.3.2.4.3..

8.4. Test Result

Not applicable to this device which was adaptive equipment and cannot operate in a non-adaptive mode.

9. Medium Utilisation (MU) factor

9.1. Block Diagram of Test Setup

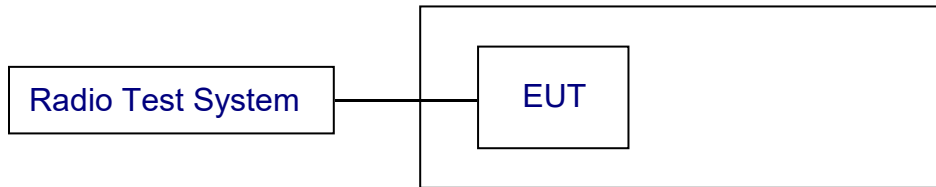

9.2. Limit

ETSI EN 300 328 V2.2.2 (2019-07) Sub-clause 4.3.2.5.3

For non-adaptive equipment using wide band modulations other than FHSS, the maximum Medium Utilization factor shall be 10 %.

This requirement does not apply to adaptive equipment unless operating in a non-adaptive mode. In addition, this requirement does not apply for equipment with a maximum declared RF Output power level of less than 10 dBm e.i.r.p. or for equipment when operating in a mode where the RF Output power is less than 10 dBm e.i.r.p.

9.3. Definition

The Medium Utilisation (MU) factor is a measure to quantify the amount of resources (Power and Time) used by non-adaptive equipment. The Medium Utilisation factor is defined by the formula:

$$\text{MU} = (P/100 \text{ mW}) \times \text{DC}$$

Where: MU is Medium Utilisation factor in %.

P is the RF output power as defined in clause 4.3.1.2.2 expressed in mW.

DC is the Duty Cycle as defined in clause 4.3.1.3.2 expressed in %.

The equipment may have a dynamic behaviour with regard to duty cycle and corresponding power level. See clause 5.4.1 e).

9.4. Test procedure

Step 1:

- Use the same stored measurement samples from the procedure described in clause 5.4.2.2.1.2.

Step 2:

- For each burst calculate the product of (Pburst / 100 mW) and the TxOn time. Pburst is expressed in mW.

TxOn

time is expressed in ms.

Step 3:

• Medium Utilization is the sum of all these products divided by the observation period (expressed in ms) which is defined in clause 4.3.1.3.2 or clause 4.3.2.4.2. This value, which shall comply with the limit given in clause 4.3.1.6.3 or clause 4.3.2.5.3, shall be recorded in the test report.

If, in case of FHSS equipment, operation without blacklisted frequencies is not possible, the power of the bursts on blacklisted hopping frequencies (for the calculation of the Medium Utilization) is assumed to be equal to the average value of the RMS power of the bursts on all active hopping frequencies.

9.5. Test Result

Not applicable to this device which cannot operation in a non-adaptive mode.



10. Occupied Channel Bandwidth

10.1. Block Diagram of Test Setup

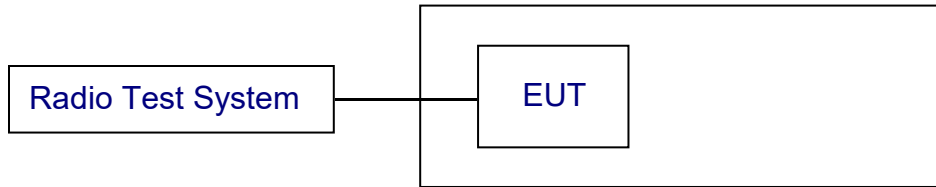

10.2. Limit

ETSI EN 300 328 V2.2.2 (2019-07) Sub-clause 4.3.2.7.3

The Occupied Channel Bandwidth shall fall completely within the band given in table 1. In addition, for non-adaptive non-FHSS equipment with e.i.r.p. greater than 10 dBm, the occupied channel bandwidth shall be less than 20 MHz.

10.3. Test procedures

Step 1:

Connect the UUT to the spectrum analyser and use the following settings:

- Centre Frequency: The centre frequency of the channel under test
- Resolution BW: ~ 1 % of the span without going below 1 %
- Video BW: 3 × RBW
- Frequency Span: 2 × Nominal Channel Bandwidth
- Detector Mode: RMS
- Trace Mode: Max Hold
- Sweep time: 1 s

Step 2:

Wait for the trace to stabilize.

Find the peak value of the trace and place the analyser marker on this peak.

Step 3:

Use the 99 % bandwidth function of the spectrum analyser to measure the Occupied Channel Bandwidth of the UUT. This value shall be recorded.

Make sure that the power envelope is sufficiently above the noise floor of the analyser to avoid the noise signals left and right from the power envelope being taken into account by this measurement.

10.4. Test Description

Mode	BT Test mode
Hopping	Off
Packet Type	Longest supported
Modulation	GFSK

10.5. Test Result

Test Condition	Test Mode	Test Channel	Ant	OBW [MHz]	FL OBW [MHz]	FH OBW [MHz]	Verdict
TNVN	BLE	2402	Ant1	1.033	2401.524	---	PASS
TNVN	BLE	2480	Ant1	1.041	---	2480.554	PASS

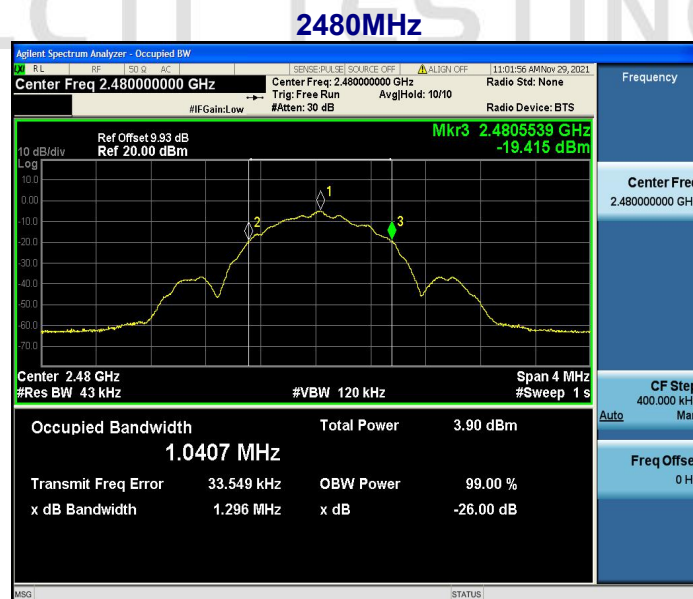
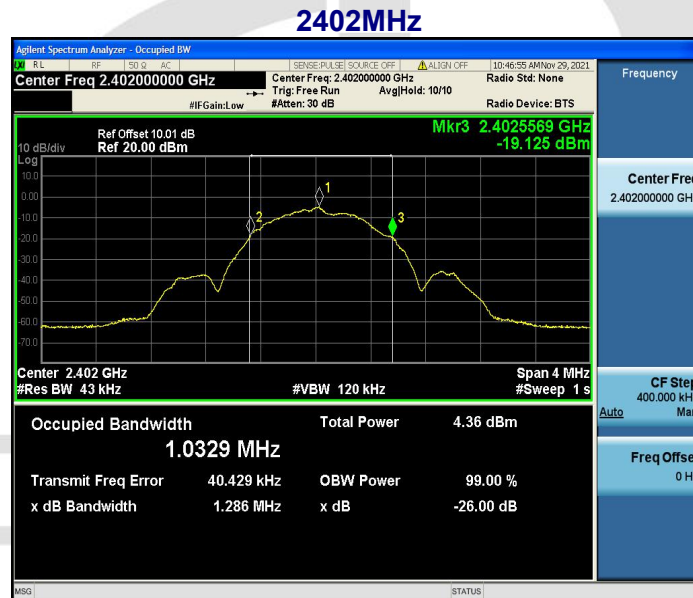

11. Transmitter unwanted emissions in the out-of-band domain

11.1. Block Diagram of Test Setup

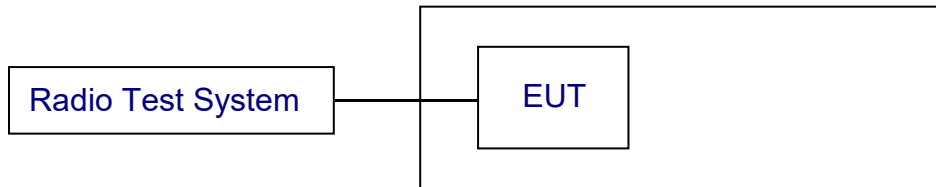

11.2. Limit

ETSI EN 300 328 V2.2.2 (2019-07) Sub-clause 4.3.2.8.3

The transmitter unwanted emissions in the out-of-band domain but outside the allocated band, shall not exceed the values provided by the mask in figure 3.

Within the band specified in table 1, the Out-of-band emissions are fulfilled by compliance with the Occupied Channel Bandwidth requirement in clause 4.3.2.7.

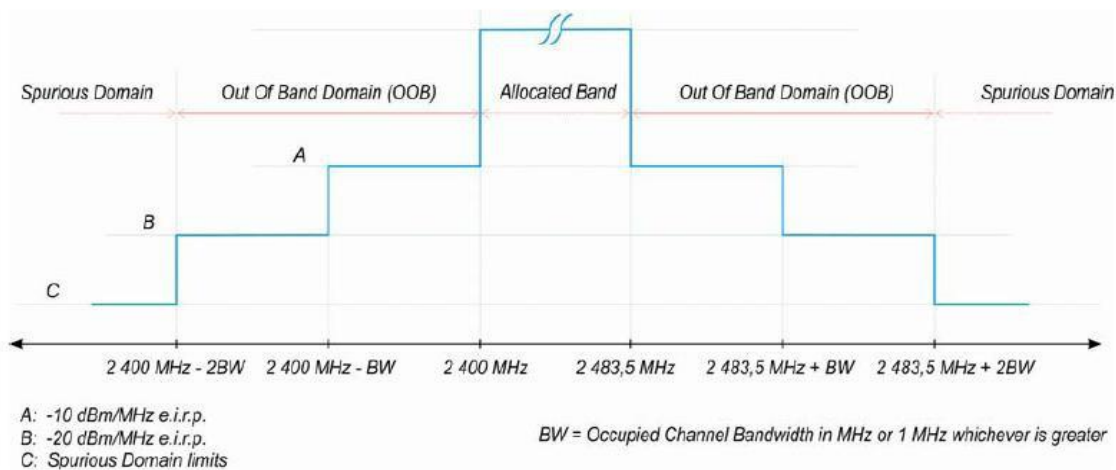

Figure 3: Transmit mask

11.3. Test procedures

The applicable mask is defined by the measurement results from the tests performed under clause 5.4.7 (Occupied Channel Bandwidth).

The Out-of-band emissions within the different horizontal segments of the mask provided in figure 1 and figure 3 shall be measured using the procedure in step 1 to step 6 below. This method assumes the spectrum analyzer is equipped with the Time Domain Power option.

Step 1:

- Connect the UUT to the spectrum analyzer and use the following settings:
 - Measurement Mode: Time Domain Power
 - Centre Frequency: 2 484 MHz

- Span: Zero Span
- Resolution BW: 1 MHz
- Filter mode: Channel filter
- Video BW: 3 MHz
- Detector Mode: RMS
- Trace Mode: Max Hold
- Sweep Mode: Single Sweep
- Sweep Points: Sweep time [μ s] / (1 μ s) with a maximum of 30000
- Trigger Mode: Video
- Sweep Time: > 120 % of the duration of the longest burst detected during the measurement of the RF Output Power.

Step 2 (segment 2483.5 MHz to 2483.5 MHz + BW):

- The measurement shall be performed and repeated while the trigger level is increased until no triggering takes place.
- For FHSS equipment operating in a normal hopping mode, the different hops will result in signal bursts with different power levels. In this case the burst with the highest power level shall be selected.
- Set a window (start and stop lines) to match with the start and end of the burst and in which the RMS power shall be measured using the Time Domain Power function.
- Select RMS power to be measured within the selected window and note the result which is the RMS power within this 1 MHz segment (2483.5 MHz to 2484.5 MHz). Compare this value with the applicable limit provided by the mask.
- Increase the centre frequency in steps of 1 MHz and repeat this measurement for every 1 MHz segment within the range 2483.5 MHz to 2483.5 MHz + BW. The centre frequency of the last 1 MHz segment shall be set to 2483.5 MHz + BW - 0.5 MHz (which means this may partly overlap with the previous 1 MHz segment).

Step 3 (segment 2483.5 MHz + BW to 2483.5 MHz + 2BW):

Change the centre frequency of the analyzer to 2484 MHz +BW and perform the measurement for the first 1 MHz segment within range 2483.5 MHz + BW to 2483.5 MHz + 2 BW. Increase the centre frequency in 1 MHz steps and repeat the measurements to cover this whole range. The centre frequency of the last 1 MHz segment shall be set to 2483.5 MHz + 2 BW - 0.5 MHz (which means this may partly overlap with the previous 1 MHz segment).

Step 4 (segment 2400 MHz - BW to 2400 MHz):

Change the centre frequency of the analyzer to 2399.5 MHz and perform the measurement for the first 1 MHz segment within range 2400 MHz - BW to 2400 MHz. Reduce the centre frequency in 1 MHz steps and repeat the measurements to cover this whole range. The centre frequency of the last 1 MHz segment shall be set to 2400 MHz - BW + 0.5 MHz (which means this may partly overlap with the previous 1 MHz segment).

Step 5 (segment 2400 MHz - 2BW to 2400 MHz - BW):

Change the centre frequency of the analyzer to 2399.5 MHz - BW and perform the measurement for the first 1 MHz segment within range 2400 MHz - 2BW to 2400 MHz - BW. Reduce the centre frequency in 1 MHz steps and repeat the measurements to cover this whole range. The centre frequency of the last 1 MHz segment shall be set to 2400 MHz - 2 BW + 0.5 MHz (which means this may partly overlap with the previous 1 MHz segment).

Step 6:

In case of conducted measurements on equipment with a single transmit chain, the declared antenna assembly gain G in dBi shall be added to the results for each of the 1 MHz segments and compared with the limits provided by the mask given in figure 1 or figure 3. If more than one antenna assembly is intended for this power setting, the antenna with the highest gain shall be considered.

In case of conducted measurements on smart antenna systems (equipment with multiple transmit chains), the measurements need to be repeated for each of the active transmit chains. The declared antenna assembly gain " G " in dBi for a single antenna shall be added to these results. If more than one antenna assembly is intended for this power setting, the antenna with the highest gain shall be considered. Comparison with the applicable limits shall be done using any of the options given below:

- Option 1: the results for each of the transmit chains for the corresponding 1 MHz segments shall be added. The additional beam forming gain " Y " in dB shall be added as well and the resulting values compared with the limits provided by the mask given in figure 1 or figure 3.
- Option 2: the limits provided by the mask given in figure 1 or figure 3 shall be reduced by $10 \times \log^{10}(A_{ch})$ and the additional beam forming gain Y in dB. The results for each of the transmit chains shall be individually compared with these reduced limits.

NOTE: A_{ch} refers to the number of active transmit chains. It shall be recorded whether the equipment complies with the mask provided in figure 1 or figure 3.

11.4. Test Description

Mode	BT Test mode
Hopping	On
Packet Type	Longest supported
Modulation	GFSK

11.5. Test Result

Test Condition	Test Mode	Test Channel	Ant	Freq [MHz]	Result [dBm]	Limit [dBm]	Verdict
TNVN	BLE	2402	Ant1	2398.434	-49.91	<=-20	PASS
TNVN	BLE	2402	Ant1	2398.467	-49.59	<=-20	PASS
TNVN	BLE	2402	Ant1	2399.467	-61.62	<=-10	PASS
TNVN	BLE	2402	Ant1	2399.500	-61.71	<=-10	PASS
TNVN	BLE	2402	Ant1	2484.000	-51.32	<=-10	PASS
TNVN	BLE	2402	Ant1	2484.033	-50.98	<=-10	PASS
TNVN	BLE	2402	Ant1	2485.033	-52.01	<=-20	PASS
TNVN	BLE	2402	Ant1	2485.066	-51.42	<=-20	PASS
TNVN	BLE	2480	Ant1	2398.419	-51.18	<=-20	PASS
TNVN	BLE	2480	Ant1	2398.459	-51.88	<=-20	PASS
TNVN	BLE	2480	Ant1	2399.459	-50.81	<=-10	PASS
TNVN	BLE	2480	Ant1	2399.500	-50.66	<=-10	PASS
TNVN	BLE	2480	Ant1	2484.000	-49.98	<=-10	PASS
TNVN	BLE	2480	Ant1	2484.041	-50.18	<=-10	PASS
TNVN	BLE	2480	Ant1	2485.041	-66.29	<=-20	PASS
TNVN	BLE	2480	Ant1	2485.081	-50.35	<=-20	PASS

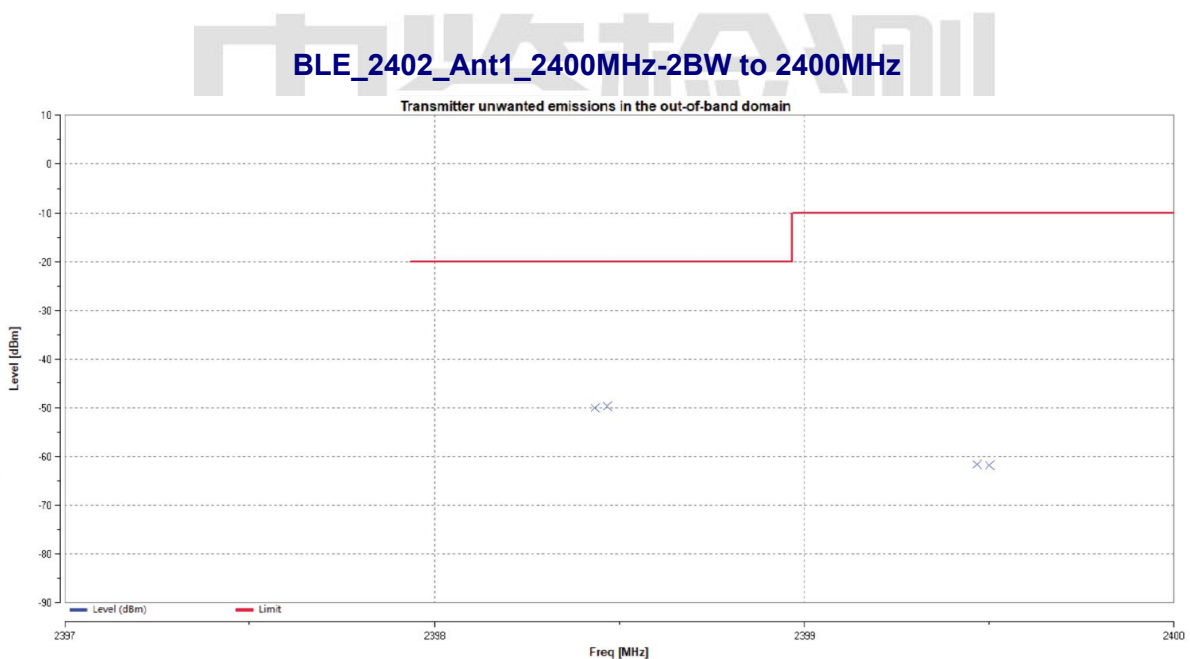

BLE_2402_Ant1_2483.5MHz to 2483.5MHz+2BW

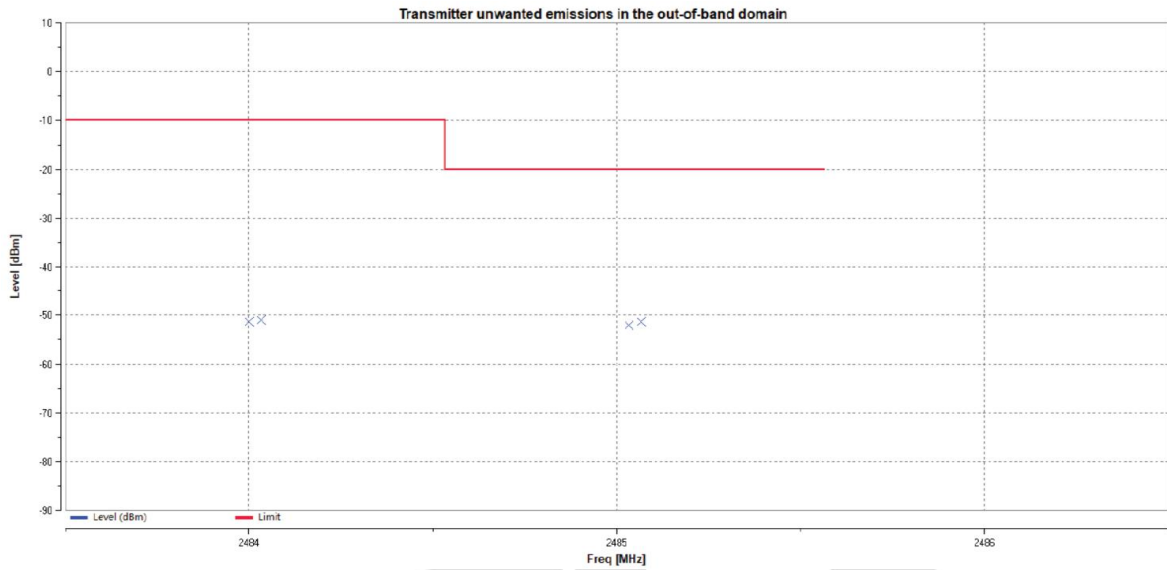

BLE_2480_Ant1_2400MHz-2BW to 2400MHz

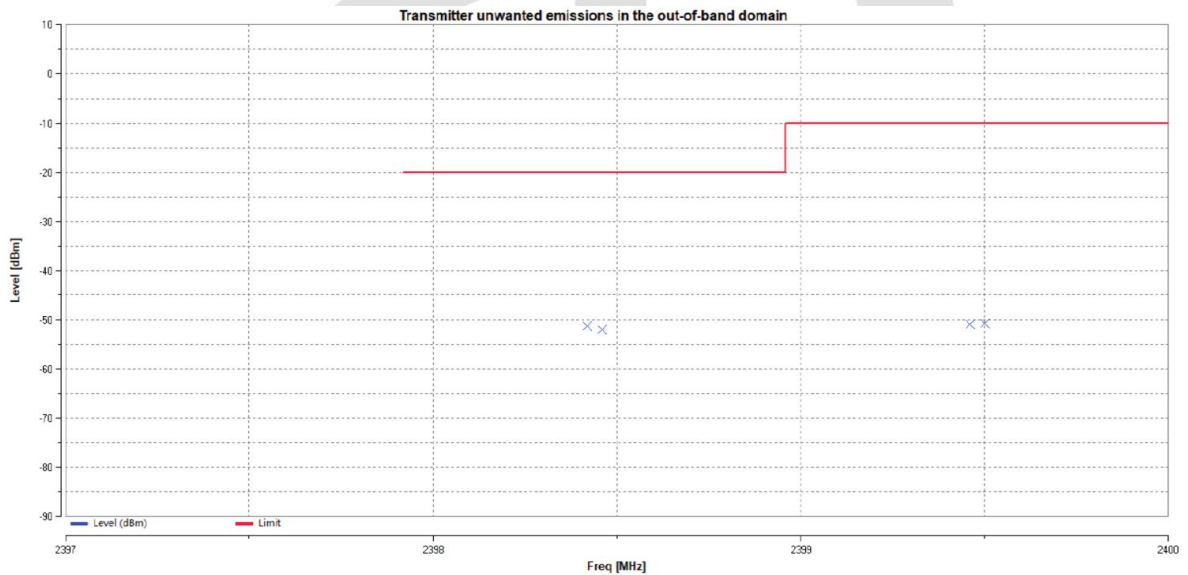

BLE_2480_Ant1_2483.5MHz to 2483.5MHz+2BW

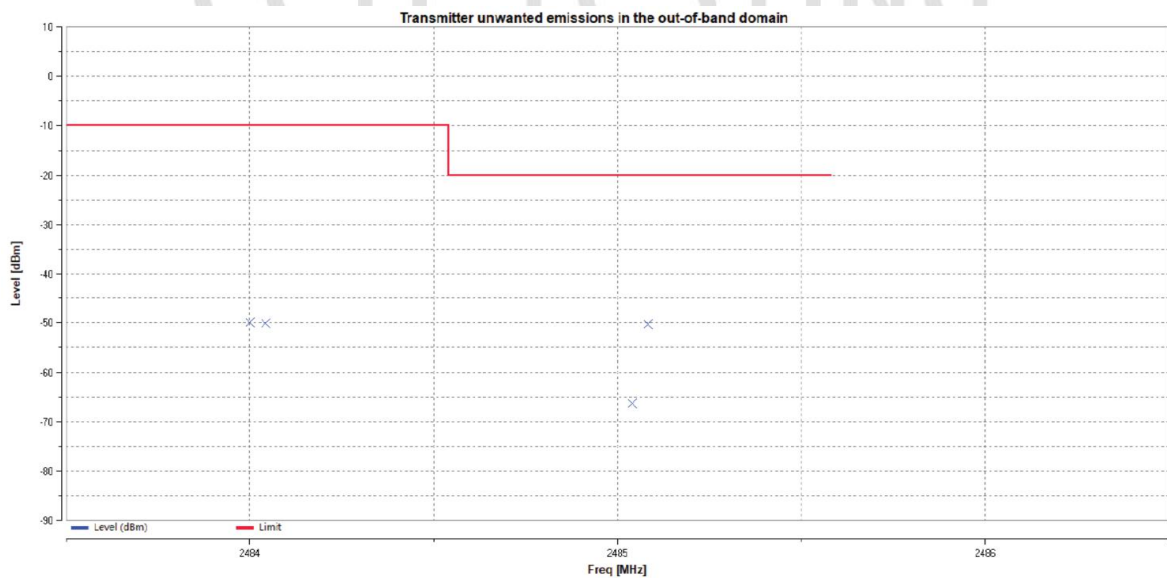

12. Transmitter unwanted emissions in the spurious domain

12.1. Block Diagram of Test Setup

(A) Radiated Emission Test Set-Up Frequency Below 1GHz.

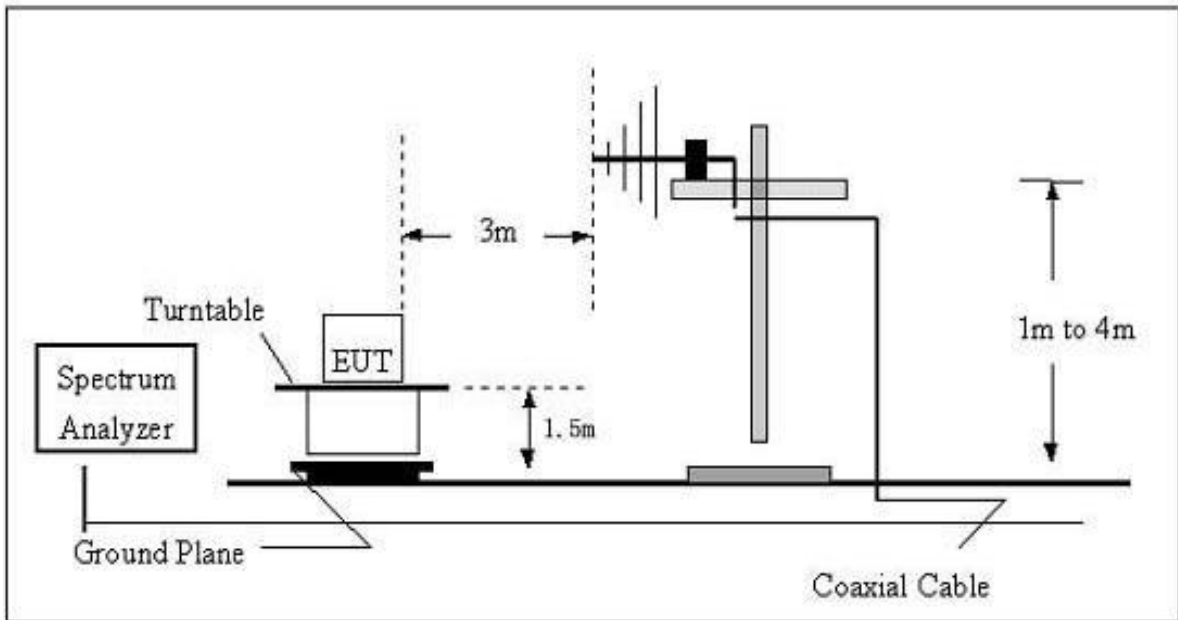

(B) Radiated Emission Test Set-Up Frequency Above 1GHz.

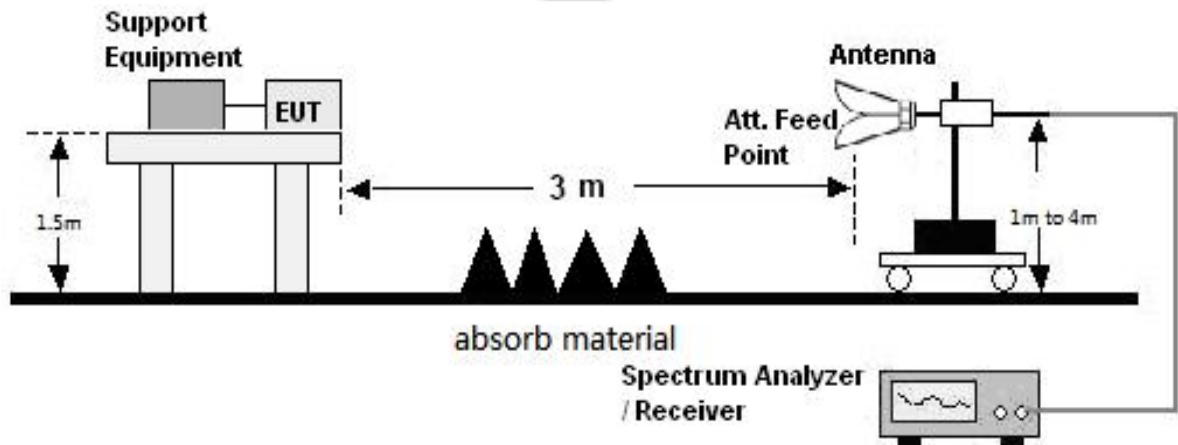

12.2. Limit

ETSI EN 300 328 V2.2.2 (2019-07) Sub-clause 4.3.2.9.3

The transmitter unwanted emissions in the spurious domain shall not exceed the values given in table 4. In case of equipment with antenna connectors, these limits apply to emissions at the antenna port (conducted). For emissions radiated by the cabinet or emissions radiated by integral antenna equipment (without antenna connectors), these limits are e.r.p. for emissions up to 1 GHz and as e.i.r.p. for emissions above 1 GHz.

Table 4: Transmitter limits for spurious emissions

Frequency range	Maximum power	Bandwidth
30 MHz to 47 MHz	-36 dBm	100 kHz
47 MHz to 74 MHz	-54 dBm	100 kHz
74 MHz to 87,5 MHz	-36 dBm	100 kHz
87,5 MHz to 118 MHz	-54 dBm	100 kHz
118 MHz to 174 MHz	-36 dBm	100 kHz
174 MHz to 230 MHz	-54 dBm	100 kHz
230 MHz to 470 MHz	-36 dBm	100 kHz
470 MHz to 694 MHz	-54 dBm	100 kHz
694 MHz to 1 GHz	-36 dBm	100 kHz
1 GHz to 12,75 GHz	-30 dBm	1 MHz

12.3. Test Procedure

30MHz ~ 1GHz:

- The Product was placed on the nonconductive turntable 1.5m above the ground in a full anechoic chamber.
- Set the spectrum analyzer/receiver in Peak detector, Max Hold mode, and 120 kHz RBW. Record the maximum field strength of all the pre-scan process in the full band when the antenna is varied between 1~4 m in both horizontal and vertical, and the turntable is rotated from 0 to 360 degrees.
- For each frequency whose maximum record was higher or close to limit, measure its QP value: vary the antenna's height and rotate the turntable from 0 to 360 degrees to find the height and degree where Product radiated the maximum emission, then set the test frequency analyzer/receiver to QP Detector and specified bandwidth with Maximum Hold Mode, and record the maximum value.

Above 1GHz:

- The Product was placed on the non-conductive turntable 1.5 m above the ground in a full anechoic chamber.
- Set the spectrum analyzer/receiver in Peak detector, Max Hold mode, and 1MHz RBW. Record the maximum field strength of all the pre-scan process in the full band when the antenna is varied in both horizontal and vertical, and the turntable is rotated

from 0 to 360 degrees.

c. For each frequency whose maximum record was higher or close to limit, measure its AV value: rotate the turntable from 0 to 360 degrees to find the degree where Product radiated the maximum emission, then set the test frequency analyzer/receiver to AV value and specified bandwidth with Maximum Hold Mode, and record the maximum value.

12.4. Test Result

Remark: We test all modulation type, and recorded the worst case mode for GFSK test.

Fre. (MHz)	ANT. Pol.	Result (dBm)	Limit	Margin	Conclusion
Below 1GHz:					
163.58	V	-52.94	-36	16.94	PASS
264.62	V	-55.36	-36	19.36	PASS
341.67	V	-56.22	-36	20.22	PASS
425.03	V	-73.27	-36	37.27	PASS
534.65	V	-77.54	-54	23.54	PASS
861.54	V	-76.93	-36	40.93	PASS
202.84	H	-72.41	-54	18.41	PASS
283.96	H	-63.07	-36	27.07	PASS
366.12	H	-74.52	-36	38.52	PASS
465.47	H	-78.83	-36	42.83	PASS
599.04	H	-68.16	-54	14.16	PASS
899.91	H	-58.48	-36	22.48	PASS
Note:					
1. Cable loss and antenna gain was combined in the calculated result.					
2. Other point of the measurements are below 20dB from the limit.					

Fre. (MHz)	ANT. Pol.	Result (dBm)	Limit	Margin	Conclusion
Above 1GHz:					
Test Mode: Low Channel					
1765.36	H	-54.51	-30	-24.51	PASS
1874.41	V	-54.17	-30	-24.17	PASS
2968.44	H	-59.78	-30	-29.78	PASS
3179.12	V	-53.02	-30	-23.02	PASS
3742.11	H	-53.18	-30	-23.18	PASS
3998.08	V	-56.04	-30	-26.04	PASS
4446.11	H	-55.56	-30	-25.56	PASS

4352.35	V	-50.29	-30	-20.29	PASS
5169.06	H	-52.26	-30	-22.26	PASS
4972.09	V	-49.77	-30	-19.77	PASS
5942.65	H	-54.15	-30	-24.15	PASS
6155.01	V	-56.33	-30	-26.33	PASS
Test Mode: High Channel					
1875.41	H	-53.84	-30	-23.84	PASS
2196.82	V	-54.95	-30	-24.95	PASS
2951.97	H	-53.27	-30	-23.27	PASS
3256.76	V	-56.43	-30	-26.43	PASS
3877.84	H	-53.46	-30	-23.46	PASS
3867.37	V	-55.57	-30	-25.57	PASS
4674.11	H	-54.28	-30	-24.28	PASS
4685.12	V	-52.99	-30	-22.99	PASS
5100.85	H	-51.35	-30	-21.35	PASS
5052.57	V	-54.46	-30	-24.46	PASS
5973.53	H	-52.65	-30	-22.65	PASS
6179.62	V	-49.11	-30	-19.11	PASS
Note: 1. Cable loss and antenna gain was combined in the calculated result. 2. Other point of the measurements are below 20dB from the limit.					

13. Receiver spurious emissions

13.1. Block Diagram of Test Setup

(A) Radiated Emission Test Set-Up Frequency Below 1GHz.

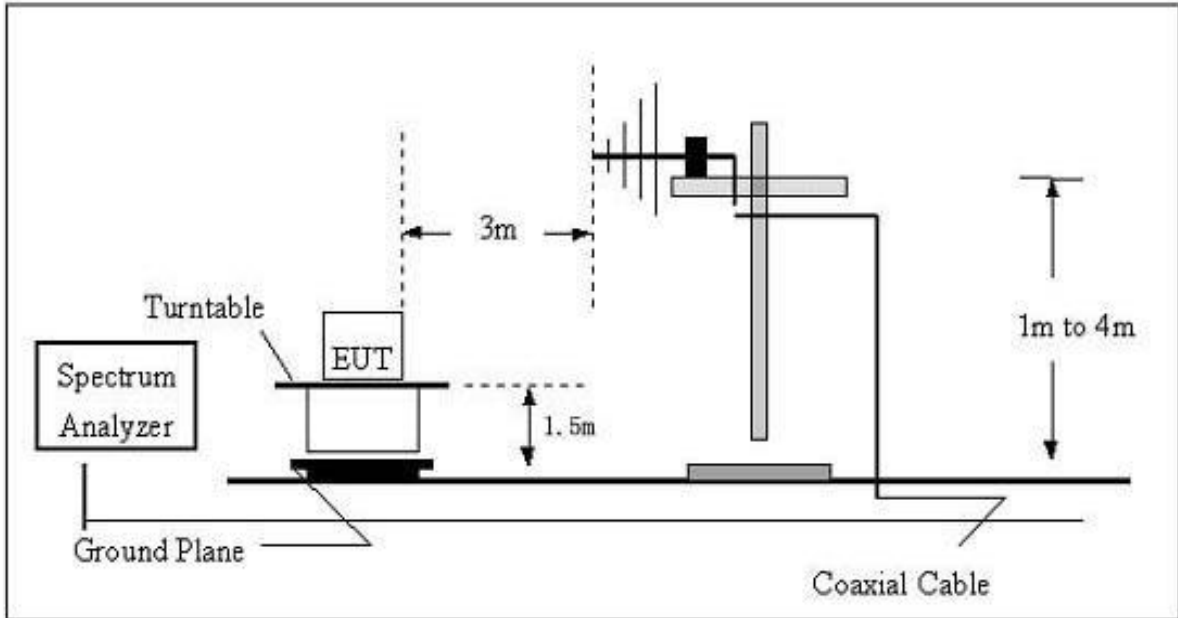

(B) Radiated Emission Test Set-Up Frequency Above 1GHz.

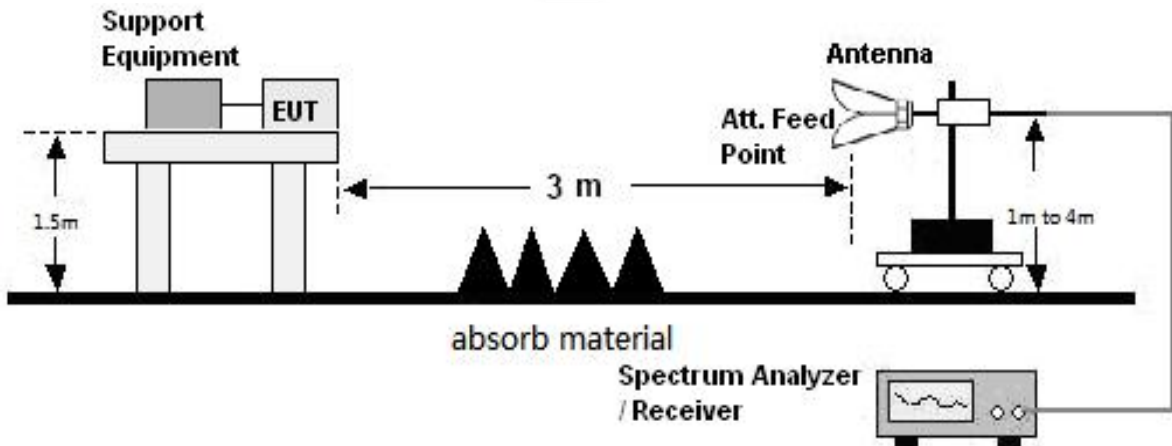

13.2. Limit

ETSI EN 300 328 V2.2.2 (2019-07) Sub-clause 4.3.2.10.3

The spurious emissions of the receiver shall not exceed the values given in table 13.

In case of non-FHSS equipment with antenna connectors, these limits apply to emissions at the antenna port (conducted). For emissions radiated by the cabinet or for emissions radiated by integral antenna equipment (without antenna connectors), these limits are e.r.p. for emissions up to 1 GHz and e.i.r.p. for emissions above 1

GHz.

Table 13: Spurious emission limits for receivers

Frequency range	Maximum power	Bandwidth
30 MHz to 1 GHz	-57 dBm	100 kHz
1 GHz to 12,75 GHz	-47 dBm	1 MHz

13.3. Test Procedure

30MHz ~ 1GHz:

- The Product was placed on the nonconductive turntable 1.5m above the ground in a full anechoic chamber.
- Set the spectrum analyzer/receiver in Peak detector, Max Hold mode, and 120 kHz RBW. Record the maximum field strength of all the pre-scan process in the full band when the antenna is varied between 1~4 m in both horizontal and vertical, and the turntable is rotated from 0 to 360 degrees.
- For each frequency whose maximum record was higher or close to limit, measure its QP value: vary the antenna's height and rotate the turntable from 0 to 360 degrees to find the height and degree where Product radiated the maximum emission, then set the test frequency analyzer/receiver to QP Detector and specified bandwidth with Maximum Hold Mode, and record the maximum value.

Above 1GHz:

- The Product was placed on the non-conductive turntable 1.5 m above the ground in a full anechoic chamber.
- Set the spectrum analyzer/receiver in Peak detector, Max Hold mode, and 1MHz RBW. Record the maximum field strength of all the pre-scan process in the full band when the antenna is varied in both horizontal and vertical, and the turntable is rotated from 0 to 360 degrees.
- For each frequency whose maximum record was higher or close to limit, measure its AV value: rotate the turntable from 0 to 360 degrees to find the degree where Product radiated the maximum emission, then set the test frequency analyzer/receiver to AV value and specified bandwidth with Maximum Hold Mode, and record the maximum value.

13.4. Test Results

Remark: We test all modulation type, and recorded the worst case mode for GFSK test.

Fre. (MHz)	ANT. Pol.	Result (dBm)	Limit	Margin	Conclusion
Below 1GHz:					
232.25	V	-76.03	-57	-19.03	PASS
259.82	V	-78.92	-57	-21.92	PASS
332.36	V	-76.11	-57	-19.11	PASS
408.15	V	-74.04	-57	-17.04	PASS
488.19	V	-77.27	-57	-20.27	PASS
872.36	V	-75.81	-57	-18.81	PASS
203.03	H	-74.45	-57	-17.45	PASS
351.91	H	-72.36	-57	-15.36	PASS
369.91	H	-73.68	-57	-16.68	PASS
473.36	H	-77.51	-57	-20.51	PASS
614.47	H	-75.13	-57	-18.13	PASS
859.04	H	-75.49	-57	-18.49	PASS
Note: 1. Cable loss and antenna gain was combined in the calculated result. 2. Other point of the measurements are below 20dB from the limit.					

Fre. (MHz)	ANT. Pol.	Result (dBm)	Limit	Margin	Conclusion
Above 1GHz:					
Test Mode: Low Channel					
2186.24	H	-63.22	-47	-16.22	PASS
2139.76	V	-69.41	-47	-22.41	PASS
3117.13	H	-67.07	-47	-20.07	PASS
2975.74	V	-67.63	-47	-20.63	PASS
3255.65	H	-66.78	-47	-19.78	PASS
3429.29	V	-65.25	-47	-18.25	PASS
4026.24	H	-64.87	-47	-17.87	PASS
3989.22	V	-63.86	-47	-16.86	PASS
4801.56	H	-67.31	-47	-20.31	PASS
5043.38	V	-67.69	-47	-20.69	PASS
6247.82	H	-68.15	-47	-21.15	PASS
6279.96	V	-66.96	-47	-19.96	PASS

Test Mode: High Channel					
2176.04	H	-62.07	-47	-15.07	PASS
2055.58	V	-64.22	-47	-17.22	PASS
2237.44	H	-65.93	-47	-18.93	PASS
2489.45	V	-67.25	-47	-20.25	PASS
3259.76	H	-69.64	-47	-22.64	PASS
3482.73	V	-66.81	-47	-19.81	PASS
3878.81	H	-63.49	-47	-16.49	PASS
3847.45	V	-67.52	-47	-20.52	PASS
5222.57	H	-65.71	-47	-18.71	PASS
5267.62	V	-66.53	-47	-19.53	PASS
6374.64	H	-65.32	-47	-18.32	PASS
6463.78	V	-65.71	-47	-18.71	PASS

Note:

1. Cable loss and antenna gain was combined in the calculated result.
2. Other point of the measurements are below 20dB from the limit.

14. Adaptivity (non-FHSS)

14.1. Block Diagram of Test Setup

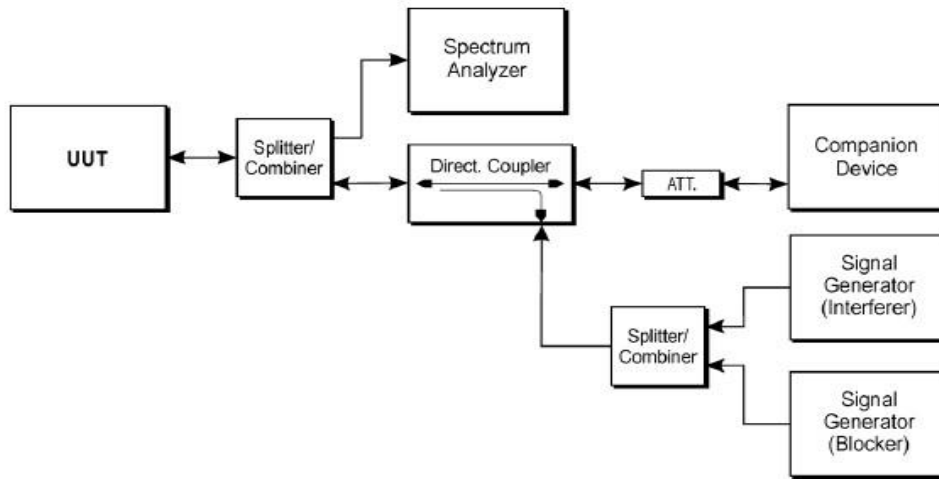

14.2. Limit

ETSI EN 300 328 V2.2.2 (2019-07) Sub-clause 4.3.2.6.2.2

Non-FHSS equipment using the non-LBT based Detect and Avoid mechanism, shall comply with the following minimum set of requirements:

- 1) During normal operation, the equipment shall evaluate the presence of a signal on its current operating channel. If it is determined that a signal is present with a level above the detection threshold defined in step 5 the channel shall be marked as 'unavailable'.
- 2) The channel shall remain unavailable for a minimum time equal to 1 s after which the channel may be considered again as an 'available' channel.
- 3) The total time during which an equipment has transmissions on a given channel without re-evaluating the availability of that channel, is defined as the Channel Occupancy Time.
- 4) The Channel Occupancy Time shall be less than 40 ms. Each such transmission sequence shall be followed by an Idle Period (no transmissions) of minimum 5 % of the Channel Occupancy Time with a minimum of 100 μ s. After this, the procedure as in step 1 needs to be repeated.
- 5) The detection threshold shall be proportional to the transmit power of the transmitter: for a 20 dBm e.i.r.p. transmitter the detection threshold level (TL) shall be equal to or less than -70 dBm/MHz at the input to the receiver assuming a 0 dBi (receive) antenna assembly. This threshold level (TL) may be corrected for the (receive) antenna assembly gain (G); however, beamforming gain (Y) shall not be taken into account. For power levels less than 20 dBm e.i.r.p., the detection threshold level may be relaxed to: $TL = -70 \text{ dBm/MHz} + 10 \times \log_{10} (100 \text{ mW} / P_{out})$ (P_{out} in

mW e.i.r.p.) 6) The equipment shall comply with the requirements defined in step 1 to step 4 of the present clause in the presence of an unwanted CW signal as defined in table 9.

Table 9: Unwanted Signal parameters

Wanted signal mean power from companion device (dBm)	Unwanted signal frequency (MHz)	Unwanted CW signal power (dBm)
-30	2 395 or 2 488,5 (see note 1)	-35 (see note 2)
NOTE 1: The highest frequency shall be used for testing operating channels within the range 2 400 MHz to 2 442 MHz, while the lowest frequency shall be used for testing operating channels within the range 2 442 MHz to 2 483,5 MHz. See clause 5.4.6.1. NOTE 2: The level specified is the level in front of the UUT antenna. In case of conducted measurements, this level has to be corrected by the actual antenna assembly gain.		

14.3. Test Procedure

The different steps below define the procedure to verify the efficiency of the non-LBT based DAA adaptive mechanism of non-FHSS equipment.

For systems using multiple receive chains only one chain (antenna port) need to be tested. All other receiver inputs shall be terminated.

Step 1:

- The UUT shall connect to a companion device during the test. The interference signal generator, the unwanted signal generator, the spectrum analyser, the UUT and the companion device are connected using a set-up equivalent to the example given by figure 5 although the interference and unwanted signal generator do not generate any signals at this point in time. The spectrum analyser is used to monitor the transmissions of both the UUT and the companion device and it should be possible to distinguish between either transmission. In addition, the spectrum analyser is used to monitor the transmissions of the UUT in response to the interfering and the unwanted signals.

- Adjust the received signal level (wanted signal from the companion device) at the UUT to the value defined in table 9 (clause 4.3.2.6.2.2). Testing of Unidirectional equipment does not require a link to be established with a companion device.

- The analyser shall be set as follows:

- RBW: \geq Occupied Channel Bandwidth (if the analyser does not support this setting, the highest available setting shall be used)

- VBW: $3 \times$ RBW (if the analyser does not support this setting, the highest available setting shall be used)

- Detector Mode: RMS
- Centre Frequency: Equal to the centre frequency of the operating channel
- Span: 0 Hz - Sweep time: > Channel Occupancy Time of the UUT
- Trace Mode: Clear/Write
- Trigger Mode: Video

Step 2:

- Configure the UUT for normal transmissions with a sufficiently high payload resulting in a minimum transmitter activity ratio ($TxOn / (TxOn + TxOff)$) of 0,3. Where this is not possible, the UUT shall be configured to the maximum payload possible.
- Using the procedure defined in clause 5.4.6.2.1.5, it shall be verified that the UUT complies with the maximum Channel Occupancy Time and minimum Idle Period defined in clause 4.3.2.6.2.2. When measuring the Idle Period of the UUT, it shall not include the transmission time of the companion device.

Step 3: Adding the interference signal

- An interference signal as defined in clause B.7 is injected on the current operating channel of the UUT. The power spectral density level (at the input of the UUT) of this interference signal shall be equal to the detection threshold defined in clause 4.3.2.6.2.2, step 5.

Step 4: Verification of reaction to the interference signal

- The spectrum analyser shall be used to monitor the transmissions of the UUT on the selected operating channel with the interfering signal injected. This may require the spectrum analyser sweep to be triggered by the start of the interfering signal.

Using the procedure defined in clause 5.4.6.2.1.5, it shall be verified that:

i) The UUT shall stop transmissions on the current operating channel being tested. The UUT is assumed to stop transmissions within a period equal to the maximum Channel Occupancy Time defined in clause 4.3.2.6.2.2, step 4.

ii) Apart from Short Control Signalling Transmissions (see iii) below), there shall be no subsequent transmissions on this operating channel for a (silent) period defined in clause 4.3.2.6.2.2, step 2. After that, the UUT may have normal transmissions again for the duration of a single Channel Occupancy Time period. Because the interference signal is still present, another silent period as defined in clause 4.3.2.6.2.2, step 2 needs to be included. This sequence is repeated as long as the interfering signal is present. To verify that the UUT is not resuming normal transmissions as long as the interference signal is present, the monitoring time may need to be 60 s or more.

iii) The UUT may continue to have Short Control Signalling Transmissions on the operating channel while the interference signal is present. These transmissions shall comply with the limits defined in clause 4.3.2.6.4.2. The verification of the Short

Control Signalling transmissions may require the analyser settings to be changed (e.g. sweep time).

iv) Alternatively, the equipment may switch to a non-adaptive mode.

Step 5: Adding the unwanted signal

- With the interfering signal present, a 100 % duty cycle CW signal is inserted as the unwanted signal. The frequency and the level are provided in table 9 of clause 4.3.2.6.2.2.
- The spectrum analyser shall be used to monitor the transmissions of the UUT on the selected operating channel. This may require the spectrum analyser sweep to be triggered by the start of the unwanted signal.
- Using the procedure defined in clause 5.4.6.2.1.5, it shall be verified that:

i) The UUT shall not resume normal transmissions on the current operating channel as long as both the interference and unwanted signals remain present.

To verify that the UUT is not resuming normal transmissions as long as the interference and unwanted signals are present, the monitoring time may need to be 60 s or more.

ii) The UUT may continue to have Short Control Signalling Transmissions on the operating channel while the interference and unwanted signals are present. These transmissions shall comply with the limits defined in clause 4.3.2.6.4.2.

The verification of the Short Control Signalling transmissions may require the analyser settings to be changed (e.g. sweep time).

Step 6: Removing the interference and unwanted signal

- On removal of the interference and unwanted signal the UUT is allowed to start normal transmissions again on this channel however, it shall be verified that this shall only be done after the period defined in clause 4.3.2.6.2.2, step 2.

Step 7:

- Step 2 to step 6 shall be repeated for each of the frequencies to be tested.

LBT based non-FHSS equipment

- Step 1 to step 7 below define the procedure to verify the efficiency of the LBT based adaptive mechanism of non-FHSS equipment. This method shall be applied to Load Based Equipment and Frame Based Equipment.

Step 1:

- The UUT shall connect to a companion device during the test. The interference signal generator, the unwanted signal generator, the spectrum analyser, the UUT and the companion device are connected using a set-up equivalent to the example given

by figure 5 although the interference and unwanted signal generator do not generate any signals at this point in time. The spectrum analyser is used to monitor the transmissions of both the UUT and the companion device and it should be possible to distinguish between either transmission. In addition, the spectrum analyser is used to monitor the transmissions of the UUT in response to the interfering and the unwanted signals.

- Adjust the received signal level (wanted signal from the companion device) at the UUT to the value defined in table 10 (clause 4.3.2.6.3.2.2) for Frame Based Equipment or in table 11 (clause 4.3.2.6.3.2.3) for Load Based Equipment. Testing of Unidirectional equipment does not require a link to be established with a companion device.
- The analyser shall be set as follows:
 - RBW: \geq Occupied Channel Bandwidth (if the analyser does not support this setting, the highest available setting shall be used)
 - VBW: $3 \times$ RBW (if the analyser does not support this setting, the highest available setting shall be used)
 - Detector Mode: RMS
 - Centre Frequency: Equal to the centre frequency of the operating channel
 - Span: 0 Hz
 - Sweep time: $>$ maximum Channel Occupancy Time
 - Trace Mode: Clear Write
 - Trigger Mode: Video

Step 2:

- Configure the UUT for normal transmissions with a sufficiently high payload resulting in a minimum transmitter activity ratio ($TxOn / (TxOn + TxOff)$) of 0,3. Where this is not possible, the UUT shall be configured to the maximum payload possible.
- For Frame Based Equipment, using the procedure defined in clause 5.4.6.2.1.5, it shall be verified that the UUT complies with the maximum Channel Occupancy Time and minimum Idle Period defined in clause 4.3.2.6.3.2.2, step 3. When measuring the Idle Period of the UUT, it shall not include the transmission time of the companion device.
- For Load Based equipment, using the procedure defined in clause 5.4.6.2.1.5, it shall be verified that the UUT complies with the maximum Channel Occupancy Time and minimum Idle Period defined in clause 4.3.2.6.3.2.3, step 2 and step 3. When measuring the Idle Period of the UUT, it shall not include the transmission time of the companion device.

For the purpose of testing Load Based Equipment referred to in the first paragraph of clause 4.3.2.6.3.2.3 (IEEE 802.11™ [i.3] or IEEE 802.15.4™ [i.4] equipment), the limits to be applied for the minimum Idle Period and the maximum Channel Occupancy Time are the same as defined for other types of Load Based Equipment

(see clause 4.3.2.6.3.2.3, step 2 and step 3). The Idle Period is considered to be equal to the CCA or Extended CCA time defined in clause 4.3.2.6.3.2.3, step 1 and step 2.

Step 3: Adding the interference signal

- An interference signal as defined in clause B.7 is injected on the current operating channel of the UUT. The power spectral density level (at the input of the UUT) of this interference signal shall be equal to the detection threshold defined in clause 4.3.2.6.3.2.2, step 5 (frame based equipment) or clause 4.3.2.6.3.2.3, step 5 (load based equipment).

Step 4: Verification of reaction to the interference signal

- The spectrum analyser shall be used to monitor the transmissions of the UUT on the selected operating channel with the interfering signal injected. This may require the spectrum analyser sweep to be triggered by the start of the interfering signal.
- Using the procedure defined in clause 5.4.6.2.1.5, it shall be verified that:

i) The UUT shall stop transmissions on the current operating channel. The UUT is assumed to stop transmissions within a period equal to the maximum Channel Occupancy Time defined in clause 4.3.2.6.3.2.2 (frame based equipment) or clause 4.3.2.6.3.2.3 (load based equipment).

ii) Apart from Short Control Signalling Transmissions, there shall be no subsequent transmissions while the interfering signal is present. To verify that the UUT is not resuming normal transmissions as long as the interference signal is present, the monitoring time may need to be 60 s or more.

iii) The UUT may continue to have Short Control Signalling Transmissions on the operating channel while the interfering signal is present. These transmissions shall comply with the limits defined in clause 4.3.2.6.4.2. The verification of the Short Control Signalling transmissions may require the analyser settings to be changed (e.g. sweep time).

iv) Alternatively, the equipment may switch to a non-adaptive mode.

Step 5: Adding the unwanted signal

- With the interfering signal present, a 100 % duty cycle CW signal is inserted as the unwanted signal. The frequency and the level are provided in table 10 (clause 4.3.2.6.3.2.2) for Frame Based Equipment or in table 11 (clause 4.3.2.6.3.2.3) for Load Based Equipment.

- The spectrum analyser shall be used to monitor the transmissions of the UUT on the selected operating channel. This may require the spectrum analyser sweep to be triggered by the start of the unwanted signal.

- Using the procedure defined in clause 5.4.6.2.1.5, it shall be verified that:
 - i) The UUT shall not resume normal transmissions on the current operating channel as long as both the interference and unwanted signals remain present. To verify that the UUT is not resuming normal transmissions as long as the interference and unwanted signals are present, the monitoring time may need to be 60 s or more.
 - ii) The UUT may continue to have Short Control Signalling Transmissions on the operating channel while the interfering and unwanted signals are present. These transmissions shall comply with the limits defined in clause 4.3.2.6.4.2. The verification of the Short Control Signalling transmissions may require the analyser settings to be changed (e.g. sweep time).

Step 6: Removing the interference and unwanted signal

- On removal of the interference and unwanted signals the UUT is allowed to start transmissions again on this channel; however, this is not a requirement and, therefore, does not require testing.

Step 7:

- Step 2 to step 6 shall be repeated for each of the frequencies to be tested.

Generic test procedure for measuring channel/frequency usage

This is a generic test method to evaluate transmissions on the operating (hopping) frequency being investigated. This test is performed as part of the procedures described in clause 5.4.6.2.1.2 to clause 5.4.6.2.1.4. The test procedure shall be as follows:

Step 1:

- The analyser shall be set as follows:
 - Centre Frequency: Equal to the hopping frequency or centre frequency of the channel being investigated.
 - Frequency Span: 0 Hz.
 - RBW: ~ 50 % of the Occupied Channel Bandwidth (if the analyser does not support this setting, the highest available setting shall be used).
 - VBW: ≥ RBW (if the analyser does not support this setting, the highest available setting shall be used).
 - Detector Mode: RMS.
 - Sweep time: > the Channel Occupancy Time. It shall be noted that if the Channel Occupancy Time is non-contiguous (for non-LBT based FHSS equipment), the sweep time shall be sufficient to cover the period over which the Channel Occupancy Time is spread out.
 - Number of sweep points: The time resolution has to be sufficient to meet the maximum measurement uncertainty of 5 % for the period to be measured. In most cases, the Idle Period is the shortest period to be measured and thereby defining the time resolution. If the Channel Occupancy Time is

non-contiguous (non-LBT based FHSS equipment), there is no Idle Period to be measured and therefore the time resolution can be increased (e.g. to 5 % of the dwell time) to cover the period over which the Channel Occupancy Time is spread out, without resulting in too high a number of sweep points for the analyser.

EXAMPLE 1: For a Channel Occupancy Time of 60 ms, the minimum Idle Period is 3 ms, hence the minimum time resolution should be $< 150 \mu\text{s}$.

EXAMPLE 2: For a Channel Occupancy Time of 2 ms, the minimum Idle Period is 100 μs , hence the minimum time resolution should be $< 5 \mu\text{s}$.

EXAMPLE 3: In case of a FHSS equipment using the non-contiguous Channel Occupancy Time approach (40 ms) and using 79 hopping frequencies with a dwell time of 3,75 ms, the total period over which the Channel Occupancy Time is spread out is 3,2 s. With a time resolution 0,1875 ms (5 % of the dwell time), the minimum number of sweep points is $\sim 17\ 000$.

- Trace mode: Clear/Write

- Trigger: Video

In case of FHSS equipment, the data points resulting from transmissions on the hopping frequency being investigated are assumed to have much higher levels compared to data points resulting from transmissions on adjacent hopping frequencies. If a clear determination between these transmissions is not possible, the RBW in step 1 shall be further reduced. In addition, a channel filter may be used.

Step 2:

- Save the trace data to a file for further analysis by a computing device using an appropriate software application or program.

Step 3:

- Identify the data points related to the frequency being investigated by applying a threshold.
- Count the number of consecutive data points identified as resulting from a single transmission on the frequency being investigated and multiply this number by the time difference between two consecutive data points. Repeat this for all the transmissions within the measurement window.
- For measuring idle or silent periods, count the number of consecutive data points identified as resulting from a single transmitter off period on the frequency being investigated and multiply this number by the time difference between two consecutive data points. Repeat this for all the transmitter off periods within the measurement window.

14.4. Test Results

Not applicable to this device which maximum RF Output power level is less than 10 dBm e.i.r.p.

15. Receiver Blocking

15.1. Block Diagram of Test Setup

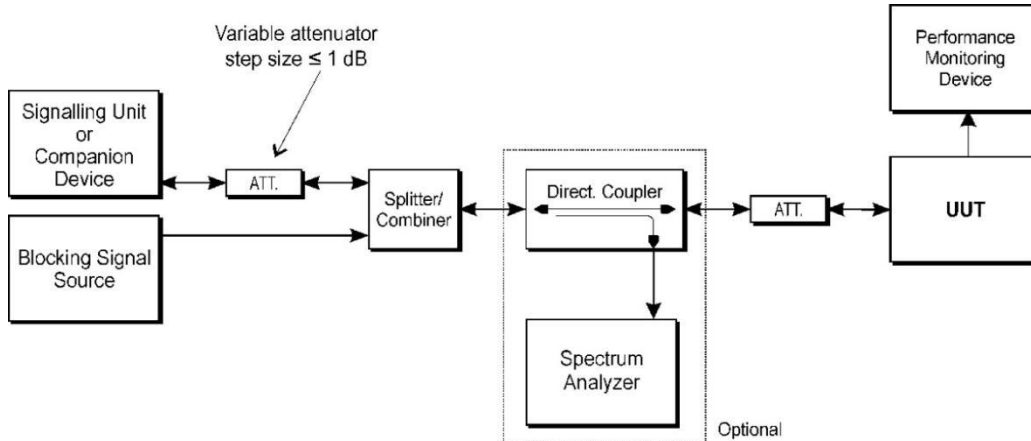

15.2. Limit

ETSI EN 300 328 V2.2.2 (2019-07) Sub-clause 4.3.2.11.4

While maintaining the minimum performance criteria as defined in clause 4.3.2.11.3, the blocking levels at specified frequency offsets shall be equal to or greater than the limits defined for the applicable receiver category provided in table 6, table 7 or table 8.

Table 6: Receiver Blocking parameters for Receiver Category 1 equipment

Wanted signal mean power from companion device (dBm) (see notes 1 and 4)	Blocking signal frequency (MHz)	Blocking signal power (dBm) (see note 4)	Type of blocking signal
$(-133 \text{ dBm} + 10 \times \log_{10}(\text{OCBW}))$ or -68 dBm whichever is less (see note 2)	2 380 2 504	-34	CW
$(-139 \text{ dBm} + 10 \times \log_{10}(\text{OCBW}))$ or -74 dBm whichever is less (see note 3)	2 300 2 330 2 360 2 524 2 584 2 674		
NOTE 1: OCBW is in Hz. NOTE 2: In case of radiated measurements using a companion device and the level of the wanted signal from the companion device cannot be determined, a relative test may be performed using a wanted signal up to $P_{\min} + 26 \text{ dB}$ where P_{\min} is the minimum level of wanted signal required to meet the minimum performance criteria as defined in clause 4.3.1.12.3 in the absence of any blocking signal. NOTE 3: In case of radiated measurements using a companion device and the level of the wanted signal from the companion device cannot be determined, a relative test may be performed using a wanted signal up to $P_{\min} + 20 \text{ dB}$ where P_{\min} is the minimum level of wanted signal required to meet the minimum performance criteria as defined in clause 4.3.1.12.3 in the absence of any blocking signal. NOTE 4: The level specified is the level at the UUT receiver input assuming a 0 dBi antenna assembly gain. In case of conducted measurements, this level has to be corrected for the (in-band) antenna assembly gain (G). In case of radiated measurements, this level is equivalent to a power flux density (PFD) in front of the UUT antenna with the UUT being configured/positioned as recorded in clause 5.4.3.2.2.			

Table 7: Receiver Blocking parameters receiver Category 2 equipment

Wanted signal mean power from companion device (dBm) (see notes 1 and 3)	Blocking signal frequency (MHz)	Blocking signal power (dBm) (see note 3)	Type of blocking signal
$(-139 \text{ dBm} + 10 \times \log_{10}(\text{OCBW}) + 10 \text{ dB})$ or $(-74 \text{ dBm} + 10 \text{ dB})$ whichever is less (see note 2)	2 380 2 504 2 300 2 584	-34	CW
NOTE 1: OCBW is in Hz. NOTE 2: In case of radiated measurements using a companion device and the level of the wanted signal from the companion device cannot be determined, a relative test may be performed using a wanted signal up to $P_{\min} + 26 \text{ dB}$ where P_{\min} is the minimum level of wanted signal required to meet the minimum performance criteria as defined in clause 4.3.1.12.3 in the absence of any blocking signal. NOTE 3: The level specified is the level at the UUT receiver input assuming a 0 dBi antenna assembly gain. In case of conducted measurements, this level has to be corrected for the (in-band) antenna assembly gain (G). In case of radiated measurements, this level is equivalent to a power flux density (PFD) in front of the UUT antenna with the UUT being configured/positioned as recorded in clause 5.4.3.2.2.			

Table 8: Receiver Blocking parameters receiver Category 3 equipment

Wanted signal mean power from companion device (dBm) (see notes 1 and 3)	Blocking signal frequency (MHz)	Blocking signal power (dBm) (see note 3)	Type of blocking signal
$(-139 \text{ dBm} + 10 \times \log_{10}(\text{OCBW}) + 20 \text{ dB})$ or $(-74 \text{ dBm} + 20 \text{ dB})$ whichever is less (see note 2)	2 380 2 504 2 300 2 584	-34	CW
NOTE 1: OCBW is in Hz. NOTE 2: In case of radiated measurements using a companion device and the level of the wanted signal from the companion device cannot be determined, a relative the test may be performed using a wanted signal up to $P_{\min} + 30 \text{ dB}$ where P_{\min} is the minimum level of wanted signal required to meet the minimum performance criteria as defined in clause 4.3.1.12.3 in the absence of any blocking signal. NOTE 3: The level specified is the level at the UUT receiver input assuming a 0 dBi antenna assembly gain. In case of conducted measurements, this level has to be corrected for the (in-band) antenna assembly gain (G). In case of radiated measurements, this level is equivalent to a power flux density (PFD) in front of the UUT antenna with the UUT being configured/positioned as recorded in clause 5.4.3.2.2.			

15.3. Test Procedure

The procedure in step 1 to step 6 below shall be used to verify the receiver blocking requirement as described in clause 4.3.1.12 or clause 4.3.2.11.

Step 1:

For non-FHSS equipment, the UUT shall be set to the lowest operating channel on which the blocking test has to be performed (see clause 5.4.11.1).

Step 2:

The blocking signal generator is set to the first frequency as defined in the appropriate table corresponding to the receiver category and type of equipment.

Step 3:

With the blocking signal generator switched off, a communication link is established between the UUT and the associated companion device using the test setup shown in figure 6.

Unless the option provided in note 2 of the applicable table referred to in clause 5.4.11.2.1 is used, the level of the wanted signal shall be set to the value provided in the table corresponding to the receiver category and type of equipment. The test procedure defined in clause 5.4.2, and more in particular clause 5.4.2.2.1.2, can be used to measure the (conducted) level of the wanted signal however no correction shall be made for antenna gain of the companion device (step 6 in clause 5.4.2.2.1.2 shall be ignored). This level may be measured directly at the output of the companion device and a correction is made for the coupling loss into the UUT.

When the option provided in note 2 of the applicable table referred to in clause 5.4.11.2.1 is used, the attenuation of the variable attenuator shall be increased in 1 dB steps to a value at which the minimum performance criteria as specified in clause 4.3.1.12.3 or clause 4.3.2.11.3 is still met. The resulting level for the wanted signal at the input of the UUT is P_{min} . This signal level (P_{min}) is increased by the value provided in note 2 of the applicable table corresponding to the receiver category and type of equipment.

Step 4:

The blocking signal at the UUT is set to the level provided in the table corresponding to the receiver category and type of equipment. Where the manufacturer has declared the actual antenna gain for each of the applicable blocking frequencies (see clause 5.4.1 m) ii)) this blocking level shall be adjusted for the difference between the in-band antenna assembly gain (G) and the actual antenna gain for the blocking frequency being tested. See also note 5 in table 6, note 4 in table 7 and note 4 in table 8 or note 5 in table 14, note 4 in table 15 and note 4 in table 16. Where the actual antenna gains at the blocking frequencies have not been declared, then the antenna gain at the blocking frequencies shall be assumed identical to the in-band antenna gain. If the performance criteria as specified in clause 4.3.1.12.3 or clause 4.3.2.11.3 is met then proceed to step 6.

Step 5:

If the performance criteria as specified in clause 4.3.1.12.3 or clause 4.3.2.11.3 is not met, step 3 and step 4 shall be repeated after that the frequency of the blocking signal set in step 2 has been increased with a value equal to the occupied channel bandwidth except:

For the blocking frequency 2 380 MHz, where this frequency offset shall be less than or equal to 10 MHz. If this frequency offset is more than 7 MHz, the level of the wanted signal shall be increased by 3 dB.

For the blocking frequency 2 503,5 MHz, where this frequency offset shall be less than or equal to 10 MHz. If this frequency offset is more than 7 MHz, the level of the wanted signal shall be decreased by 3 dB.

If the performance criteria as specified in clause 4.3.1.12.3 or clause 4.3.2.11.3 is not met, step 3 and step 4 shall be repeated after that the frequency of the blocking signal set in step 2 has been decreased with a value equal to the occupied channel bandwidth except:

For the blocking frequency 2 380 MHz, where this frequency offset shall be less than or equal to 10 MHz. If this frequency offset is more than 7 MHz, the level of the wanted signal shall be decreased by 3 dB.

For the blocking frequency 2 503,5 MHz, where this frequency offset shall be less than or equal to 10 MHz. If this frequency offset is more than 7 MHz, the level of the wanted signal shall be increased by 3 dB.

If the performance criteria as specified in clause 4.3.1.12.3 or clause 4.3.2.11.3 is still not met, the UUT fails to comply with the Receiver Blocking requirement and step 6 and step 7 are no longer required.

It shall be recorded in the test report whether the shift of blocking frequencies as described in the present step was used.

Step 6:

Repeat step 4 and step 5 for each remaining combination of frequency and level for the blocking signal as provided in the table corresponding to the receiver category and type of equipment.

Step 7:

For non-FHSS equipment, repeat step 2 to step 6 with the UUT operating at the highest operating channel on which the blocking test has to be performed (see clause 5.4.11.1).

Step 8:

It shall be assessed and recorded in the test report whether the UUT complies with the Receiver Blocking requirement.

15.4. Test Results

Test Frequency (MHz)	Wanted signal mean power from companion device (dBm)	Blocking signal frequency (MHz)	Blocking signal power (dBm)	PER (%)
2402	-68.86	2380	-34	0.07
	-68.86	2504		0.22
	-68.86	2300		0.95
	-68.86	2584		0.21
2480	-68.83	2380		0.63
	-68.83	2504		0.81
	-68.83	2300		0.64
	-68.83	2584		0.52

Note: EUT is Receiver Category 2 equipment.

APPENDIX I -- EUT PHOTOGRAPHS

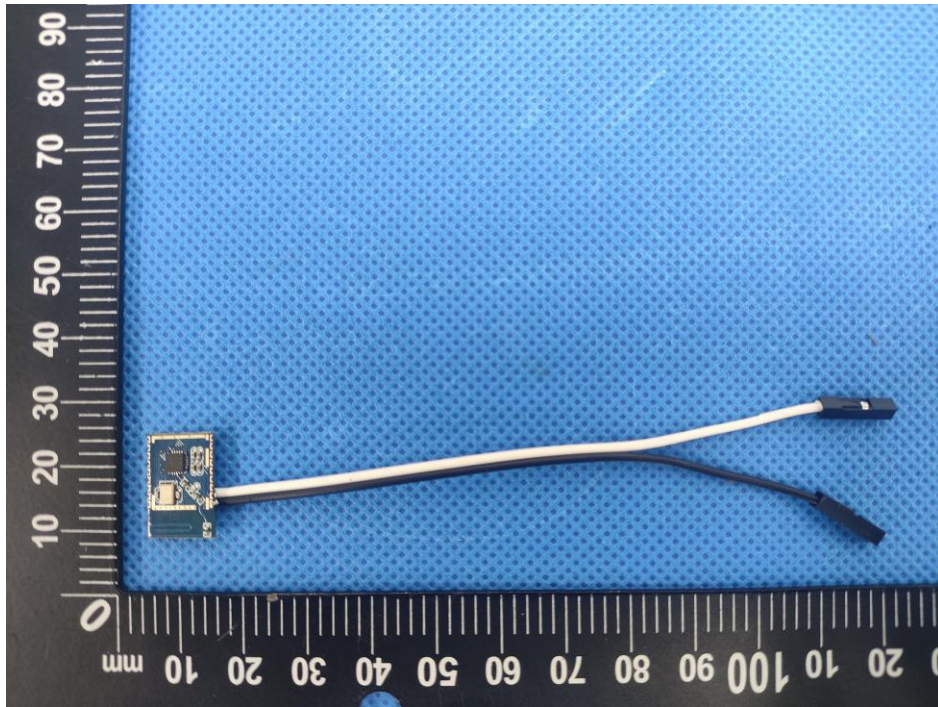

EUT Photo 1

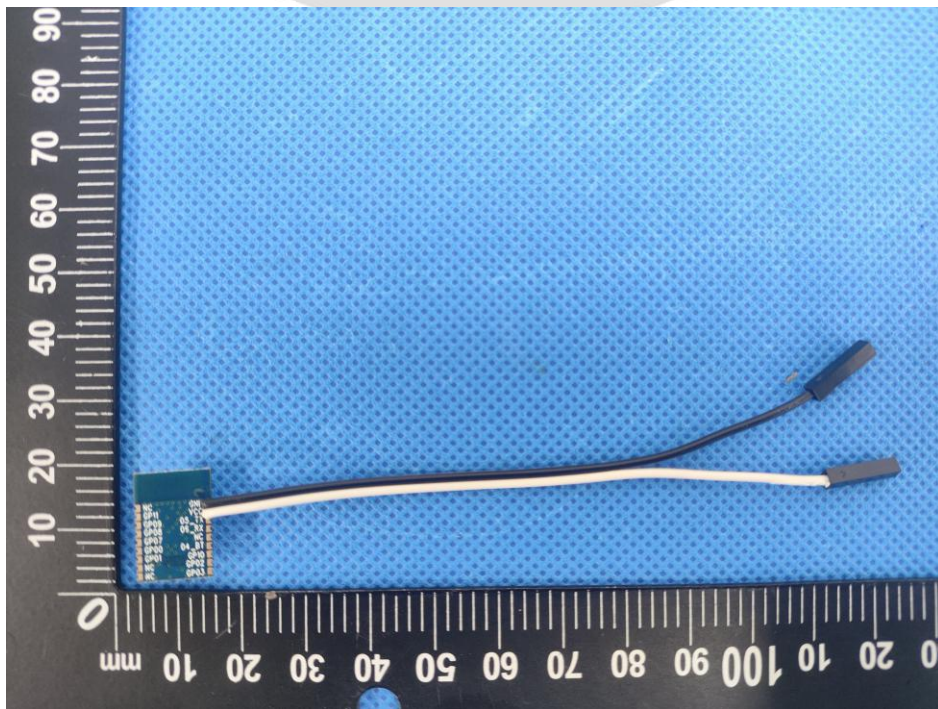

EUT Photo 2

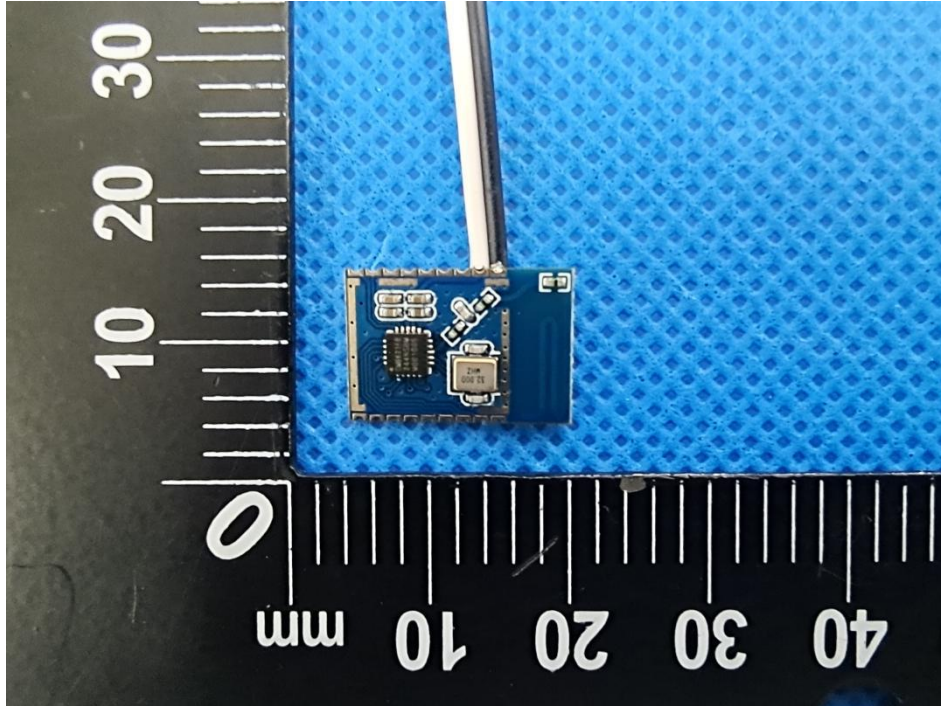

EUT Photo 3

中鉴检测
CCTI TESTING

APPENDIX II -- EUT TEST PHOTOGRAPHS

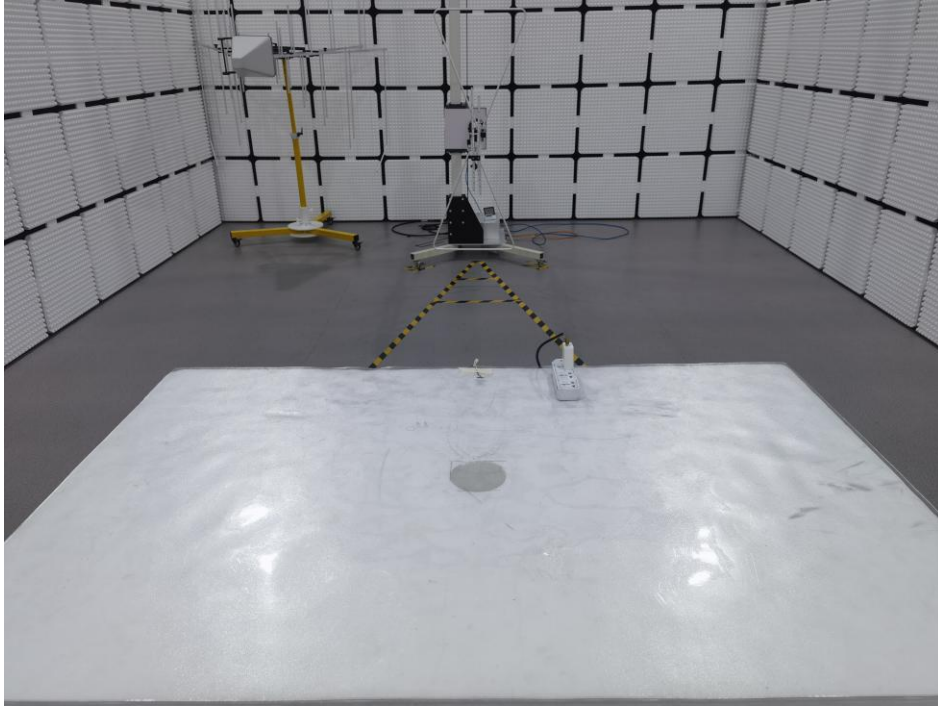

EUT Test Photo

***** END OF REPORT *****

中鉴检测
CCTI TESTING